

BA448CF-P
PROFIBUS PA
Intrinsically safe
Panel mounting
8 variable
Fieldbus Indicator
Issue: 2

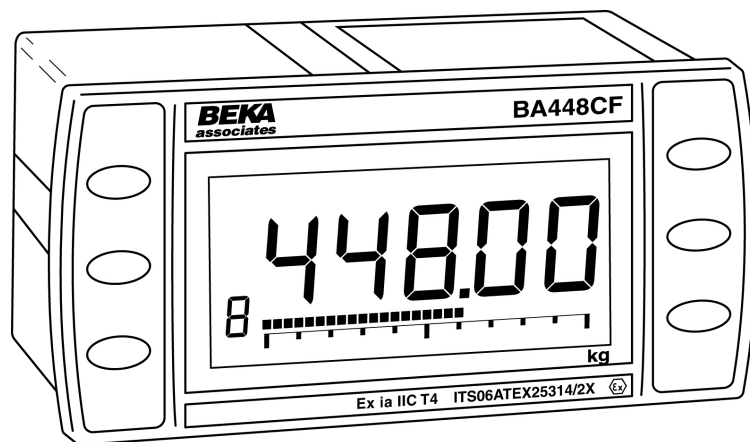

CONTENTS

1. Description

- 1.1 Documentation

2. Operation

- 2.1 Error messages

3. Intrinsic Safety Certification

- 3.1 ATEX certificate
- 3.2 Zones, gas groups and T rating
- 3.3 Fieldbus connection
- 3.4 Certification label Information

4. System Design for Hazardous Area

- 4.1 FISCO Systems
- 4.2 Non-FISCO Systems

5. Installation

- 5.1 Location
- 5.2 Installation procedure
- 5.3 EMC

6. Configuration

- 6.1 Configuration menus
- 6.2 Node configuration menu
 - 6.2.1 Enter fieldbus address
 - 6.2.2 Access code
 - 6.2.3 Change from node to listener
 - 6.2.4 Reset to node factory defaults
- 6.3 Listener configuration menu
 - 6.3.1 Access
 - 6.3.2 Summary of configuration functions.
- 6.4 Description of listener menu functions
 - 6.4.1 Scan fieldbus segment
 - 6.4.2 List configured input parameters.
 - 6.4.3 Enter address & display parameters.
 - 6.4.4 Enable selected input
 - 6.4.5 Enter source address
 - 6.4.6 Enter destination address
 - 6.4.7 Enter Index
 - 6.4.8 Decimal point position
 - 6.4.9 Configuration of bargraph
 - 6.4.10 Scale numeric display
 - 6.4.11 Access code for listener configuration menu.
 - 6.4.12 Change from fieldbus listener to fieldbus node.
 - 6.4.13 Reset the listener to factory defaults.

7. Maintenance

- 7.1 Fault finding during commissioning
- 7.2 Fault finding after commissioning
- 7.3 Servicing
- 7.4 Routine maintenance
- 7.5 Guarantee
- 7.6 Customer comments

8. Accessories

- 8.1 Scale marking
- 8.2 Tag number
- 8.3 Fieldbus Interface Guide

Appendix 1

FM Approval for use in the USA and
cFM Approval for use in Canada.

Appendix 2

IECEx certification

The BA448CF-P is CE marked to show compliance with the European Explosive Atmospheres Directive 94/9/EC and the European EMC Directive 2004/108/EC

1. DESCRIPTION

The BA448CF-P fieldbus indicator is an intrinsically safe, PROFIBUS PA instrument that may be configured as a fieldbus node or as a fieldbus listener. It can display up to eight fieldbus process variables on a five digit LCD and a 31 segment analogue bargraph. The instrument is bus powered so no additional power supply is required and it has PROFIBUS PA User Organisation approval, certificate Z01505.

Fieldbus node configuration may be performed by either a User PRM data download or by a DPV1 configurator, and if required, the instrument address may be entered via the front panel push buttons.

When configured as a fieldbus listener, the BA448CF-P is not visible to the fieldbus host and can only be configured using the push buttons on the front of the instrument.

Housed in a robust 72 x 144 panel mounting DIN enclosure, the BA448CF-P fieldbus indicator has an IP66 front panel and is supplied with a gasket to seal the joint between the instrument & the panel.

The instrument is intrinsically safe and has been certified by European Notified Body Intertek Testing and Certification Ltd (ITS) to the ATEX Directive 94/9/EC for use in explosive gas atmospheres.

The BA448CF-P also has intrinsic safety and nonincendive FM and cFM Approval allowing installation in the USA and Canada – see Appendix 1.

For international applications the BA448CF-P fieldbus indicator has IECEx intrinsic safety approval – see Appendix 2.

The instrument's communication protocol is shown on the rear of the instrument. The '-P' order code suffix also indicates the protocol but is not shown on the instrument certification label. There is an alternative version of the fieldbus display, order code BA448CF-F for use on FOUNDATION™ fieldbus networks.

1.1 Documentation

This instruction manual describes ATEX system design and installation of the BA448CF-P Fieldbus Indicator. System design information for FM, cFM and IECEx installations is shown in separate appendices to this manual.

For additional node configuration information please refer to the *BEKA PROFIBUS PA Display – Fieldbus Interface Guide* which is available from the BEKA sales office, or may be downloaded from www.beka.co.uk

2. OPERATION

The BA448CF-P indicator can display up to eight pre-configured PROFIBUS PA process variables designated in-1 to in-8. The operator can select which variable is displayed using the ▼ and ▲ push buttons which scroll the display through the eight inputs. A numeric annunciator on the left hand side of the display shows which of the eight inputs is currently being displayed.

2.1 Error messages

'no ConF'	No inputs have been configured or are enabled.
'no dAtA'	No data is being received with the current configuration.

3. INTRINSIC SAFETY CERTIFICATION

3.1 ATEX certificate

The BA448CF-P has been issued with an EC-Type Examination Certificate by Notified Body Intertek Testing and Certification Ltd (ITS) confirming compliance with the European ATEX Directive 94/9/EC for Group II, Category 1G, gas atmospheres, Ga Ex ia IIC T4. The instrument bears the Community Mark and, subject to local codes of practice, may be installed in any of the European Economic Area (EEA) member countries. ATEX certificates are also acceptable for installations in Switzerland.

This manual describes ATEX installations in explosive gas atmospheres that conform with EN 60079:Part14 Electrical Installation in Hazardous Areas. When designing systems for installation outside the UK, the local Code of Practice should be consulted.

3.2 Zones, gas groups and T rating

The BA448CF-P has been issued with EC Type Examination certificate ITS06ATEX25314/2X confirming that it complies with the requirements for Group II Category 1G Ga Ex ia IIC T4 (Tamb –40 to 70°C) specified in the ATEX Directive. When connected to a suitable certified system the BA448CF-P may be installed in:

Zone 0	explosive gas air mixture continuously present. Note: Special conditions for safe use apply see section 5.1
Zone 1	explosive gas air mixture likely to occur in normal operation.
Zone 2	explosive gas air mixture not likely to occur, and if it does will only exist for a short time.

Be used with gases in groups:

- Group A propane
- Group B ethylene
- Group C hydrogen

Having a temperature classification of:

- T1 450°C
- T2 300°C
- T3 200°C
- T4 135°C

At an ambient temperature between -40 and +70°C.

Note: minimum guaranteed operating temperature is -20°C.

3.3 Fieldbus connection

The BA448CF-P Indicator is powered and communicates via the fieldbus, which is connected to terminals 1 and 2. These are non-polarised, comply with the Fieldbus Intrinsically Safe Concept (FISCO) defined in EN 60079 Part 27 and have separate entity parameters shown below:

	FISCO	Entity
U _i	= 17.5V dc	22.0V dc
I _i	= 380mA dc	250mA dc
P _i	= 5.32W	1.2W

The maximum equivalent capacitance and inductance at terminals 1 & 2 is:

$$C_i = 0$$

$$L_i = 8\mu\text{H}$$

3.4 Certification Label Information

The certification information label is fitted to the top outer surface of the enclosure. It shows details of the ATEX certification and a statement that the instrument is a FISCO Field Device, plus BEKA associates name and location. IECEx approval information is also included. The label may also contain non-European certification information. The instrument serial number and year of manufacture are shown on the rear panel adjacent to the terminals.



4. SYSTEM DESIGN FOR HAZARDOUS AREAS

4.1 FISCO Systems

The BA448CF-P may be connected to any ATEX certified FISCO compliant fieldbus segment, providing the segment can supply the additional 13mA required to power the instrument.

Fig 1 shows a typical fieldbus segment. To comply with FISCO requirements, the power supply, terminators, field devices and the interconnecting cables must conform to EN 60079 part 27.

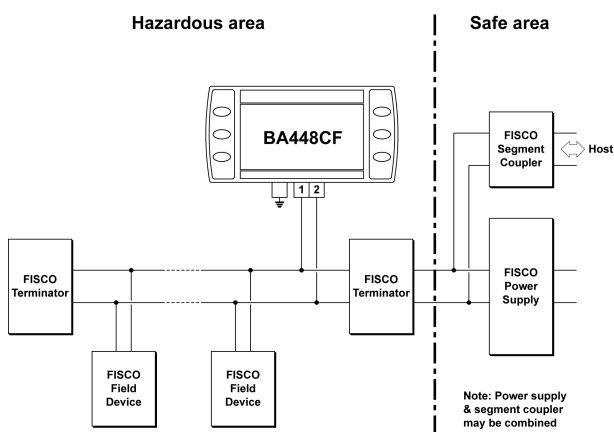

Fig 1 FISCO fieldbus system

4.2 Non-FISCO Systems

For non-FISCO applications the BA448CF-P Fieldbus Indicator has a higher voltage entity intrinsic safety input parameter allowing connection to a wide range of fieldbus segments.

The BA448CF-P Fieldbus Indicator may be connected to any intrinsically safe segment providing:

The device powering the fieldbus segment is ATEX certified and has output parameters equal to or less than:

$$U_o = 22\text{V dc}$$

$$I_o = 250\text{mA dc}$$

$$P_o = 1.2\text{W}$$

The segment can provide an additional 13mA to power the Fieldbus Indicator.

Note: The equivalent capacitance C_i of the BA448CF-P Fieldbus Indicator is zero and the equivalent inductance is insignificant. Therefore these BA448CF-P safety parameters do not need to be considered.

5. INSTALLATION

5.1 Location

The BA448CF-P is housed in a robust aluminium enclosure with a toughened glass window mounted in a Noryl bezel. The front of the instrument provides IP66 protection and a gasket seals the joint between the instrument enclosure and the panel. The instrument may be installed in any panel providing the environmental limits shown in the specification are not exceeded.

Fig 2 shows the overall dimensions of the BA448CF-P and the panel cut-out. To achieve an IP66 seal between the instrument enclosure and the panel, the smaller cut-out must be used and the instrument secured with four panel mounting clips.

CAUTION

Installation in Zone 0

When installed in a Zone 0 potentially explosive atmosphere requiring apparatus of Category 1G, the indicator shall be installed such that even in the event of rare incidents, an ignition source due to impact or friction between the aluminium enclosure at the rear of the instrument mounting panel and iron/steel is excluded.

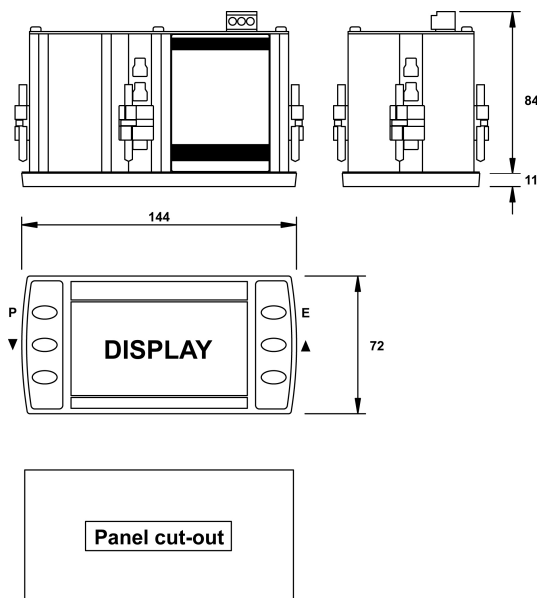

Cut-out Dimensions

DIN 43 700

138.0 +1.0/-0.0 x 68.0 +0.7/-0.0

To achieve an IP66 seal between instrument enclosure and panel

136.0 +0.5/-0.0 x 66.2 +0.5/0.0

Fig 2 BA448CF-P dimensions

5.2 Installation Procedure

- Insert the BA448CF-P into the instrument panel cut-out from the front of the panel.
- Fix panel mounting clips to opposite sides of the instrument and tighten until the instrument is secure. Four clips are required to achieve an IP66 seal between the instrument enclosure and the panel.
- Connect the panel wiring to the rear terminal block as shown in Fig 3. To simplify installation, the terminals are removable so that panel wiring can be completed before the instrument is installed.

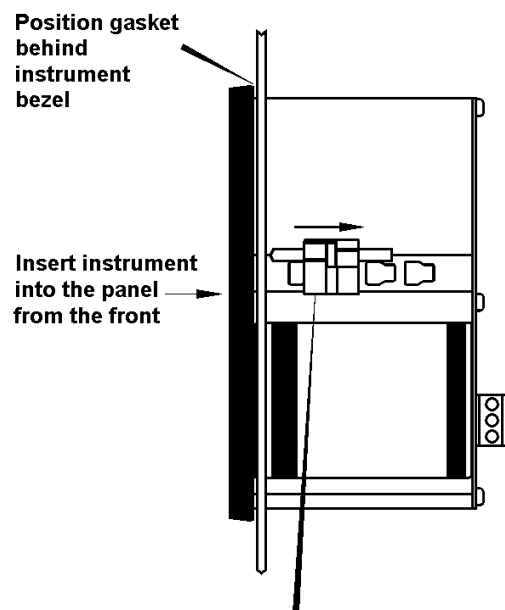

Slide panel mounting clip into the slotted rail on the side of the enclosure. Four clips are required to achieve an IP66 seal between instrument and panel.

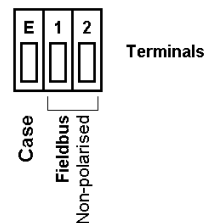

Fig 3 Installation and terminal connections

5.3 EMC

The BA448CF-P complies with the requirements of the European EMC Directive 2004/108/EEC. For specified immunity, all wiring should be in screened twisted pairs with the screens earthed at one point in the safe area.

6. CONFIGURATION

The BA448CF-P 8 variable PROFIBUS PA indicator may be configured as a fieldbus node or as a fieldbus listener. When used as a fieldbus node the indicator is configured via the fieldbus host although the instrument address may be entered via the front panel push buttons using the menu shown in Fig 4. For detailed node conditioning information please refer to the *BEKA PROFIBUS PA Display – Fieldbus Interface Guide* which may be downloaded from the BEKA website www.beka.co.uk

As a fieldbus listener, the BA448CF-P is not visible to the fieldbus host and can only be configured via the front panel push buttons using the menu shown in Fig 6.

Throughout this manual the BA448CF-P push buttons are identified **P** **E** **▼** **▲** and legends displayed by the instrument are shown within inverted commas e.g. 'CodE' and 'Enb'.

6.1 Configuration menus

The configuration menus are separated into two sections, fieldbus node and fieldbus listener. Both contain the 'tYPE' function that enables transfer between the two. Unless otherwise requested when ordered, all PROFIBUS PA BA448CF-P instruments are supplied as a fieldbus node with default configuration but can easily be reconfigured on-site.

6.2 Node configuration menu

The node configuration menu is shown in Fig 4. Access to the menu is obtained by operating the **P** and **E** buttons simultaneously. If the BA448CF-P is not protected by an access code the first parameter 'Addr' will be displayed. If the instrument is protected by an access code, 'CodE' will be displayed first. Pressing **P** will allow the four digit security code to be entered digit by digit using the **▼** or **▲** button to adjust the flashing digit and **P** to move control to the next digit. When the correct code has been entered, pressing **E** will cause the first parameter 'Addr' to be displayed. If an incorrect code is entered, or no button is pressed for ten seconds, the BA448CF-P will automatically return to the display mode.

6.2.1 Enter fieldbus address 'Addr'

This function enables the fieldbus address of the BA448CF-P to be entered via the push buttons. Select 'Addr' in the node menu using the **▼** or **▲** button and press **P** to enter the function. This will reveal the existing three digit decimal address with the left hand digit flashing which may be changed by operating the **▼** or **▲** button. When set as required operating the **P** button will transfer control to the next digit that may be adjusted in the same way.

When all digits are set as required operating the **E** button will enter the new address and the indicator will restart in the display mode after completing the initialisation sequence. If the address is not changed, operating the **E** button will return the display to the 'Addr' prompt in the node configuration menu.

6.2.2 Access code for configuration menu 'CodE'

Access to the node configuration menu may be protected by a four digit security code which must be entered to gain access. New instruments are supplied configured with the default code 0000 which disables this protection and allows unrestricted access to the configuration menu.

To enter a new access code select 'CodE' in the node configuration menu by operating the **▼** or **▲** button. To enter the function press **P** which will reveal the current access code with one digit flashing. The code may be changed using the **▼** or **▲** button to adjust the flashing digit and the **P** button to move control to the next digit. When the required code has been selected, press **E** to enter the selection and return to the 'CodE' prompt in the configuration menu. The revised access code will be activated when the transmitter is returned to the display mode.

If the access code is lost please contact BEKA associates.

6.2.3 Change from node to listener 'tYPE'

This function enables the instrument to be changed from a fieldbus node to a fieldbus listener. Select 'tYPE' in the node configuration menu using the **▼** or **▲** button. To enter the function press **P** which will show that the instrument is configured as a fieldbus node, to change to a fieldbus listener press the **▼** or **▲** button which will toggle the display to 'LStr'. To prevent accidental changes this request must be confirmed by operating the **P** button and entering '5urE'. The instrument will display '0000' with the first digit flashing, using the **▼** or **▲** button set the flashing digit to '5' and press the **P** button to move control to the next digit which should be set to 'u'. When the four letters of '5urE' have been entered, operating the **E** button will cause the instrument to restart as a fieldbus listener in the display mode.

CAUTION

All the instrument's node configuration information will be lost when it is changed from a fieldbus node to a fieldbus listener.

Please refer to the quick set-up procedure in the *BEKA PROFIBUS PA Display – Fieldbus Interface Guide*.

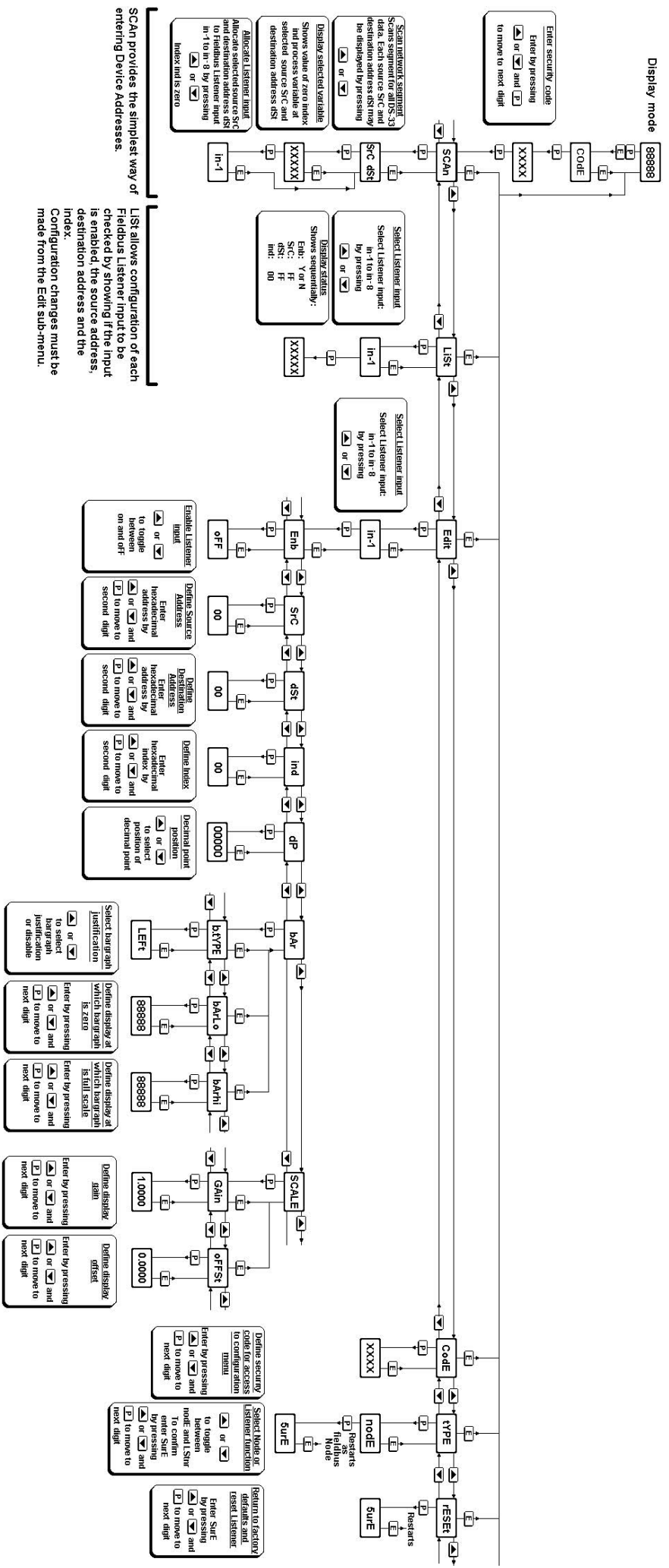

Fig 6 Listener configuration menu

6.3.1 Access

Access to the listener configuration menu is obtained by operating the **P** and **E** buttons simultaneously. If the BA448CF-P listener configuration menu is not protected by an access code the first parameter 'SCAn' will be displayed. If the BA448CF-P is protected by an access code, 'CodE' will be displayed first. Pressing **P** will allow the four digit security code to be entered digit by digit using the ▼ or ▲ button to adjust the flashing digit and **P** to move control to the next digit. When the correct code has been entered, pressing **E** will cause the first parameter 'SCAn' to be displayed. If an incorrect code is entered, or no button is pressed for ten seconds, the indicator will automatically return to the display mode.

Section 6.3.2 contains a summary of each configuration function including a cross reference to a more detailed description.

6.3.2 Summary of listener configuration functions

Instrument display	Summary of function
'SCAn'	<p>Scan fieldbus segment Identifies all data sources on the fieldbus segment to which the listener is connected and enables selected data to be allocated to one of the eight listener inputs in-1 to in-8. See section 6.4.1</p>
'LiSt'	<p>List configured input parameters For each of the eight BA448CF-P listener inputs, in-1 to in-8 shows if the input is enabled; Source Address; Destination Address and the Index which have been allocated. Parameters can not be changed from within this function. See section 6.4.2</p>
'Edit'	<p>Enter addresses and display parameters Sub-menu which allows known fieldbus device addresses to be entered and all display parameters adjusted for each of the eight fieldbus listener inputs. See section 6.4.3</p>
'Enb'	<p>Enable selected input Enables each of the eight listener inputs in-1 to in-8 to be enabled or disabled without affecting any parameters. See section 6.4.4</p>
'SrC'	<p>Enter Source Address Allows hexadecimal fieldbus device source address for each of the eight listener inputs in-1 to in-8 to be entered. See section 6.4.5</p>
'dSt'	<p>Enter Destination Address Allows hexadecimal fieldbus device destination address for each listener input in-1 to in-8 to be entered. See section 6.4.6</p>
'ind'	<p>Enter Index Allows hexadecimal index for specified fieldbus source address to be entered for each listener input in-1 to in-8. See section 6.4.7</p>
'dP'	<p>Decimal point position Defines position of displayed decimal point for each listener input in-1 to in-8. See section 6.4.8</p>
'bAr'	<p>Configuration of bargraph Defines the bargraphs justification and the digital display at which the bargraph is zero and full scale for each listener input in-1 to in-8. See section 6.4.9</p>
'SCALE'	<p>Scale numeric display Applies zero offset and scale factor to the numeric display for each listener input in-1 to in-8. See section 6.4.10</p>
'CodE'	<p>Access code for listener configuration menu. Enters a four digit security access code for configuration menu. Default code 0000 disables this function. See section 6.4.11</p>
'tYPE'	<p>Change from listener to node Enables the instrument to be conditioned as a fieldbus listener or a fieldbus node. See section 6.4.12</p>
'rESET'	<p>Reset to listener factory defaults Returns the BA448CF-P listener to factory defaults. See section 6.4.13</p>

6.4 Description of listener menu functions

This section contains a detailed description of each function in the listener configuration menu. It should be read in conjunction with Fig 6.

6.4.1 Scan fieldbus segment 'SCAN'

If the Device Addresses of a data source are not known, the 'SCAN' function provides a simple way to identify them. This function scans the fieldbus segment to which the BA448CF-P listener is connected and identifies all the data sources. To aid identification the value of the process variable with a zero index i.e. the first five bytes in the data string at the address may be pre-viewed.

The BA448CF-P listener only supports DS-33 formatted data (status+float) which is the usual format for analogue process variables. The 'SCAN' function will identify, irrespective of format, all data sources on the segment whose destination address is five bytes long. When pre-viewed, non DS-33 formatted data will produce a 'no dAt' error message.

'SCAN' is the first function displayed when entering the configuration menu, or it may be selected from within the menu by operating the ▼ or ▲ button. To scan the fieldbus segment to which the listener is connected for all data sources press **P** which will reveal the hexadecimal source address and destination address of the first data source found as shown in Fig 5. If there is more than one data source, operating the ▼ or ▲ button will scroll through all of them.

If there are no data sources on the fieldbus segment the BA448CF-P listener will display 'noSrC'.

When the source and destination addresses of a data source are displayed, to aid identification the value of the process variable with a zero index i.e. the first five bytes in the data string may be pre-viewed by operating the **P** button. If this confirms that it is the required address, it may be allocated to one of the eight BA448CF-P listener inputs in-1 to in-8. To select the required listener input, press **P** which will display the first input in-1. Operating the ▼ or ▲ button will scroll the display through the other inputs. When the required input is displayed pressing **E** will allocate the selected data source address to the selected input and return the display to the source and destination addresses from which another data source address may be selected. When a data source address is allocated to a listener input any previous allocation will be overwritten.

If the required process variable has an index above 5 i.e. it is not the first five bytes in the data string, the required index should be entered via the 'ind' function in the Edit sub-menu which is described in section 6.4.7

6.4.2 List configured input parameters 'LiSt'

The 'LiSt' function enables the Source Address, Destination Address and Index allocated to each listener input to be viewed without danger of it being accidentally changed.

The 'LiSt' function may be selected from within the menu by operating ▼ or ▲ button. To enter the function press **P** which will display the listener input currently selected in the display mode, other inputs may be selected using the ▼ or ▲ button. Operating the **P** button will cause the following parameters for the selected input to be displayed sequentially:

Display	Explanation
'Enb :Y or N'	Input Enabled yes or no
'SrC :00'	Source Address
'dSt :00'	Destination Address
'ind :00'	Index

The display then automatically returns to the selected BA448CF-P listener input from where another input may be selected.

If one of the eight BA448CF-P Listener's inputs in-1 to in-8 has not had a Source Address, Destination Address and Index allocated to it, 'LiSt' will show both addresses as 'FF' and the index 'ind' as '00'.

6.4.3 Enter address & display parameters 'Edit'

The 'Edit' sub-menu may be selected from within the menu by operating ▼ or ▲ button. To enter the function press **P** which will display the listener input currently selected in the display mode, other listener inputs may be selected using the ▼ or ▲ button. When the required input has been selected operating the **P** button will enter the edit sub-menu at 'Enb' for the selected input.

6.4.4 Enable selected input 'Enb'

'Enb' turns the listener input selected in the Edit function on or off without affecting the conditioning. To enter the function press **P** which will reveal whether the selected input is 'on' or 'oFF'. Operating the ▼ or ▲ buttons will toggle between the two conditions. When set as required operating the **E** button will enter the selection and return to the 'Enb' prompt in the edit sub-menu.

6.4.5 Enter source address 'SrC'

This function allows a known fieldbus device source address to be entered and allocated to the listener input selected in the edit function. To enter the function press **P** which will reveal the existing two digit hexadecimal address with one digit flashing which may be changed by operating the ▼ or ▲ button. When set as required operating the **P** button will transfer control to the second digit that may be adjusted in the same way. When both digits are set as required operating the **E** button will enter the selection and return to the 'SrC' prompt in the edit sub-menu.

6.4.6 Enter destination address 'dSt'

This function allows a known fieldbus device destination address to be entered and allocated to the listener input selected in the Edit function. To enter the function press **P** which will reveal the existing two digit hexadecimal address with one digit flashing which may be changed by operating the ▼ or ▲ button. When set as required operating the **P** button will transfer control to the second digit that may be adjusted in the same way. When both digits are set as required operating the **E** button will enter the selection and return to the 'dSt' prompt in the edit sub-menu.

6.4.7 Enter Index 'ind'

Index defines the location of the required process variable in the data string. The 'ind' function allows a known Index for the selected fieldbus Source Address to be entered and allocated to the BA448CF-P listener input selected in the Edit function. The data location is manufacturer specific and can not be automatically determined; the device documentation should therefore be consulted. To enter the function press **P** which will reveal the existing two digit hexadecimal Index with one digit flashing which may be changed by operating the ▼ or ▲ button. When set as required operating the **P** button will transfer control to the second digit that may be adjusted in the same way. When both digits are set as required operating the **E** button will enter the selection and return to the 'ind' prompt in the edit sub-menu.

6.4.8 Decimal point position 'dP'

This defines the position the decimal point in the numeric display. To enter the function press **P** which will reveal the existing decimal point position. Operating the ▼ or ▲ button will move the decimal point to the required position, omit it, or activate all the decimal points which automatically provides maximum resolution in the display mode irrespective of the numeric value. When positioned as required, operating the **E** button will enter the selection and return to the 'dP' prompt in the edit sub-menu.

6.4.9 Configuration of bargraph display 'bAr'

This function contains three sub-functions that enable the bargraph, justify its position and define the relationship between the bargraph and the instrument's numeric display.

Sub-function 'b.tYPE' enables the bargraph to be left, centre or right justified, or to be turned off. Sub-functions 'bArLo' and 'bArHi' define the listener's numeric display at which the bargraph starts and is at full scale.

The 'bAr' function may be selected from within the edit sub-menu by operating the ▼ or ▲ button. To enter the function press **P** which will display the 'b.tYPE' sub-function, pressing **P** again will reveal the existing bargraph justification. The ▼ or ▲ button will scroll through the four options, when the required justification is displayed, pressing **E** will enter the selection and return the display to the 'b.tYPE' prompt in the edit sub-menu from which 'bArLo' may be selected using the ▼ or ▲ button.

'bArLo' defines the listener's numeric display at which the bargraph starts, to enter the function press **P** which will reveal the existing setting. The display may be changed using the ▼ or ▲ button to adjust the flashing digit and the **P** button to move control to the next digit. When the required starting display has been selected, press **E** to return to the 'bArLo' prompt in the edit sub-menu from which the 'bArHi' function may be selected.

'bArHi' defines the listener's numeric display at which the bargraph is full scale, to enter the function press **P** which will reveal the existing setting. The display may be changed using the ▼ or ▲ button to adjust the flashing digit and the **P** button to move control to the next digit. When the required display has been selected, press **E** twice to enter the new values and return to the 'bAr' prompt in the edit sub-menu.

Note: If the 'dP' function has been set to provide automatic maximum resolution irrespective of the displayed value, it may be necessary to manually position the decimal point before adjusting 'bArLo' or 'bArHi'. This can be achieved by repeatedly operating the **P** button until the activated decimal point flashes, the decimal point can then be positioned using either the ▼ or ▲ button. Pressing the **P** button again will return control to one of the digits.

6.4.10 Scale numeric display 'SCALE'

A scaling factor 'Gain' and an offset 'oFFSt' may be applied to the fieldbus process variable using this function, thus allowing the listener to display the fieldbus process variable in alternative units.

The 'SCALE' function may be selected from within the edit sub-menu by operating the ▼ or ▲ button. To enter the function press **P** which will display the 'GAin' sub-function, pressing **P** again will reveal the existing gain with one digit flashing. This flashing digit may be changed by operating the ▼ or ▲ button; when adjusted the **P** button will move control to the next digit or to the decimal point which can be positioned using the ▼ or ▲ button. When 'GAin' has been set to the required value operating the **E** button will enter the selection and return to the 'GAin' prompt in the sub-menu from where the 'oFFSt' function can be selected using the ▼ or ▲ button.

To enter the 'oFFSt' function press **P** which will reveal the existing offset with one digit flashing. Again the flashing digit may be changed by operating the ▼ or ▲ button and the **P** button will move control to the next digit or to the decimal point. When 'oFFSt' has been set to the required value operating the **E** button will enter the selection and return to the 'oFFSt' prompt in the sub-menu. Three operations of the **E** button will return to the 'Edit' function in the main configuration menu.

6.4.11 Access code for listener configuration menu 'CodE'

Access to the listener configuration menu may be protected by a four digit security code which must be entered to gain access. New instruments are supplied configured with the default code 0000 which disables this protection and allows unrestricted access to the configuration menu.

To enter a new access code select 'CodE' in the configuration menu by operating the ▼ or ▲ button. To enter the function press **P**, this will reveal the current access code with one digit flashing. The code may be changed using the ▼ or ▲ button to adjust the flashing digit and the **P** button to move control to the next digit. When the required code has been selected, press **E** to enter the selection and return to the 'CodE' prompt in the configuration menu. The revised access code will be activated when the transmitter is returned to the display mode.

If the access code is lost please contact BEKA associates.

6.4.12 Change from fieldbus listener to fieldbus node 'tYPE'

This function enables the BA448CF-P to be conditioned as a fieldbus node or as a fieldbus listener. To change the function of the instrument select 'tYPE' in the listener configuration menu using the ▼ or ▲ button and press **P** to enter which will show that the instrument is configured as a fieldbus listener. To change to a fieldbus node press the ▼ or ▲ button which will toggle the display to 'nodE'.

To prevent accidental changes this request must be confirmed by operating the **P** button and entering '5urE'. The instrument will display '0000' with the first digit flashing, using the ▼ or ▲ button set the flashing digit to '5' and press the **P** button to move control to the next digit which should be set to 'u'. When the four letters of '5urE' have been entered, operating the **E** button will result in the instrument restarting in the display mode as a fieldbus node.

CAUTION

All the instrument's listener configuration information will be lost when it is changed from a fieldbus listener to a fieldbus node.

6.4.13 Reset the listener to factory defaults 'rESEt'

The BA448CF-P listener may be reset to the factory defaults that are shown below:

Security Code	0000 (disabled)
---------------	-----------------

For each of the eight inputs:

Decimal point	XXX.XX
Bar Type	Left
Bar lower limit	0.0
Bar Upper limit	100.0
Gain	1.0
Offset	0.0

To reset the BA448CF-P listener select 'rESEt' in the configuration menu by operating the ▼ or ▲ button. To enter the function press **P**, this will reveal '0000' with the left hand digit flashing. To prevent accidental use of this function, '5urE' must be entered to confirm that the instrument is to be reset.

Using the ▼ or ▲ button set the flashing digit to '5' and press the **P** button to move control to the next digit which should be set to 'u'. When the four letters of '5urE' have been entered operating the **E** button will reset the BA448CF-P to the factory defaults. Any existing configuration and addresses will be lost when the listener is reset.

7. MAINTENANCE

7.1 Fault finding during commissioning

If a BA448CF-P fails to function during commissioning the following procedure should be followed:

Symptom	Cause	Check:
No Display	Instrument not correctly connected or powered.	9 to 22V between terminals 1 & 2.
Display shows '9.9.9.9.9' with all decimal points flashing; all bargraph segments activated and bargraph scale flashing.	Value over-range	Variable source Decimal point configuration.
Display shows '-9.9.9.9.9' with all decimal points flashing; no bargraph segments activated and bargraph scale flashing.	Value under-range	Variable source Decimal point configuration
Display alternates between value and the word 'bAd'. Bargraph flashes.	Status of fieldbus variable has a quality of 'BAD' or a fault state is active. Display has not yet received data.	Variable source Fieldbus configuration.
Bargraph scale flashes.	Variable is outside the limits defined for the bargraph.	Bargraph configuration.
All display segments activated.	Display is initialising.	This is normal operation, after a few seconds the firmware version will be displayed prior to entering the display mode.

7.2 Fault finding after commissioning

ENSURE PLANT SAFETY BEFORE STARTING MAINTENANCE

Live maintenance is permitted on intrinsically safe equipment installed in a hazardous area, but only certified test equipment should be used unless a gas clearance certificate is available.

If a BA448CF-P fails after it has been functioning correctly, the table shown in section 7.1 may help to identify the cause of the failure.

If this procedure does not reveal the cause of the fault, it is recommended that the instrument is replaced.

7.3 Servicing

We recommend that faulty BA448CF-P Fieldbus Indicators be returned to BEKA associates or to our local agent for repair.

7.4 Routine maintenance

The mechanical and electrical condition of the instrument should be regularly checked. Initially annual inspections are recommended, but the inspection frequency should be adjusted to suit the environmental conditions.

7.5 Guarantee

Instruments which fail within the guarantee period should be returned to BEKA associates or our local agent. It is helpful if a brief description of the fault symptoms is provided.

7.6 Customer comments

BEKA associates is always pleased to receive comments from customers about our products and services. All communications are acknowledged and whenever possible, suggestions are implemented.

8. ACCESSORIES

8.1 Scale marking

BA448CF-P indicators are fitted with a blank escutcheon around the liquid crystal display. If specified when the instrument is ordered, this can be supplied printed with units of measurement and a scale for the horizontal bargraph.

8.2 Tag number

The BA448CF-P can be supplied with a thermally printed tag number on the rear panel adjacent to the terminals.

8.3 BEKA PROFIBUS PA Display – Fieldbus Interface Guide.

The *BEKA PROFIBUS PA Display – Fieldbus Interface Guide* contains commissioning information for the BA448CF. A copy may be requested from the BEKA sales office or downloaded from the BEKA web site at www.beka.co.uk

APPENDIX 1
FM approval for use in the USA and
cFM Approval for use in Canada

A1.0 Factory Mutual Approval

For installations in the USA and Canada the BA448CF-P has FM and cFM intrinsic safety and nonincendive approvals, project identification 3027031 and 3027031C. Copies of the Certificates of Compliance are available from BEKA associates sales office and www.beka.co.uk.

A1.1 Intrinsic safety approval

The BA448CF-P is approved to FM Class 3610 intrinsic safety standard for use in hazardous (classified) locations. Installations must comply with BEKA associates Control Drawing CI410-12, which is attached to this Appendix, ANSI/ISA RP12.06.01 'Installation of Intrinsically Safe Systems for Hazardous (Classified) Locations' and with the National Electrical Code ANSI/NFPA70.

Canadian installations must comply with the Canadian Electrical Code C22.2 and with BEKA associates Control Drawing CI410-12 which is attached to this Appendix.

The BA448CF-P has a T4 rating at ambient temperatures up to +70°C and may be used with the following gases:

Intrinsic Safety	
Division 1 or 2	
Class I	Group A & B Group C Group D
Zone 0, 1 or 2	
Class 1	Group IIC Group IIB Group IIA

The FM and cFM entity parameters are identical to the ATEX parameters and, like the ATEX certification, confirm that the BA448CF-P complies with the FISCO Field Device requirements specified in IEC60079-27. The intrinsically safe system shown in Fig 1 of this manual may therefore be used for installations in the USA and Canada, providing the fieldbus power supply, terminators, Zener barriers and galvanic isolators are FM Approved for US installations and cFM or CSA Approved for Canadian installations. All installations must comply with BEKA associates Control Drawing CI410-12.

FM and cFM Approval also allows the BA448CF-P to be connected to non-FISCO systems using the entity concept – see section 4.2 of this manual.

A1.2 Nonincendive approval



The BA448CF-P is also Class 3611 nonincendive approved by Factory Mutual allowing it to be installed in Division 2 hazardous (classified) locations without the need for Zener barriers or galvanic isolators. US installations must comply with the BEKA associates Control Drawing CI410-13, which is attached to this Appendix, and with the National Electrical Code ANSI/NFPA70.

Canadian nonincendive installations must comply with the Canadian Electrical Code C22.2 and with BEKA associates Control Drawing CI410-13 which is attached to this Appendix.

The FM and cFM Nonincendive Approvals also allow the BA448CF-P fieldbus indicator to be connected to any appropriately certified FNICO compliant fieldbus segment.

The BA448CF-P has a T4 rating at ambient temperatures up to +70°C and may be used with the following gases:

Nonincendive	
Division 2	
Class I	Group A & B Group C Group D
Zone 2	
Class I	Group IIC Group IIB Group IIA

Iss.		Date		Modification		Ckd.		Appd.					
1		28.03.2006		First release									
2		15.09.2009		Provision for alternative instrument titles added.									
													
<p>12. The BA418CF may alternatively be titled: BA448CF Fieldbus Indicator BA448CL Fieldbus Listener BA428CF Fieldbus Set Point Station</p> <p><u>FISCO Rules</u></p> <p>The FISCO Concept allows the interconnection of intrinsically safe apparatus to associated apparatus not specifically examined in such combination. The criterion for such interconnection is that the voltage (V_{max}), the current (I_{max}) and the power (P_{max}) which intrinsically safe apparatus can receive and remain intrinsically safe, considering faults, must be equal or greater than the voltage (U_o, V_o or V_t), the current (I_o, I_{sc} or I_t) and the power (P_o) which can be provided by the associated apparatus (supply unit). In addition the maximum unprotected residual capacitance (C_i) and inductance (L_i) of each apparatus (other than terminators) connected to the Fieldbus must be less than or equal to 5nF and 10uH respectively.</p> <p>In each I.S. Fieldbus segment only one active source, normally the associated apparatus, is allowed to provide the necessary power for the Fieldbus system. The allowed voltage (U_o, V_o or V_t) of the associated apparatus used to supply the bus cable must be limited to the range 14Vdc to 24Vdc. All other equipment connected to the bus cable has to be passive, meaning that the apparatus is not allowed to provide energy to the system, except a leakage current of 50µA for each connected device. Separately powered equipment needs galvanic isolation to ensure the intrinsically safety Fieldbus circuit remains passive.</p> <p>The cable used to interconnect the devices needs to comply with the following parameters: Loop resistance R': 15....150Ω/km Inductance per unit length L':0.4....1mH/km</p> <p>Capacitance per unit length C': 80....200nF/km $C' = C' \text{ line/line} + 0.5 C' \text{ line/screen}$, if both lines are floating or $C' = C' \text{ line/line} + C' \text{ line/screen}$, if the screen is connected to one line. Length of spur cable: max. 30m Length of trunk cable: max. 1km Length of splice: max = 1m</p> <p>Terminators At the end of each trunk cable an FM Approved line terminator with the following parameters is suitable: $R = 90....100\Omega$ $C = 0 \dots 2.2\mu F$</p> <p>System evaluation The number of passive devices like transmitters, actuators, connected to a single bus segment is not limited due to I.S. reasons. Furthermore, if the above rules are respected, the inductance and the capacitance of the cable need not be considered and will not impair the intrinsic safety of the installation.</p> <p>Notes. 1. The intrinsic safety FISCO concept allows the interconnection of FM Approved Intrinsically Safe devices with FISCO parameters not specifically examined in combination as a system when: U_o or V_o or $V_t \leq V_{max}$, I_o, I_{sc} or $I_t \leq I_{max}$, $P_o \leq P_i$.</p> <p>For Canadian installations the intrinsic safety FISCO concept allows the interconnection of CFM or CSA Approved Intrinsically Safe devices with FISCO parameters not specifically examined in combination as a system when: U_o or V_o or $V_t \leq V_{max}$, I_o, I_{sc} or $I_t \leq I_{max}$, $P_o \leq P_i$.</p>													
Date						Title		Drawn		Checked		Scale	
28.03.2006						FM Approvals Control Drawing for Intrinsically Safe BA414DF & BA418CF Fieldbus Indicators		RC				NTS	
1								Drawing No.		CI410-12			
2								Sheet 3					

Includes BA444DF see note 11

APPENDIX 2 IECEX Certification

A2.0 The IECEx Certification Scheme

IECEX is a global certification scheme for explosion protected products which aims to harmonise international certification standards.

For additional information about the IECEx certification scheme and to view the BEKA associate certificates, please visit www.iecex.com

A2.1 IECEx Certificate of Conformity

The BA448CF-P Fieldbus Indicator has been issued with an IECEx Certificate of Conformity number IECEx ITS 06.0013X which specifies the following certification codes and marking:

Ex ia IIC T4 Ga
FISCO Field Device Ex ia IIC T4
Ta = -40°C to 70 °C

See below for details of safe use in Zone 0.

CAUTION

Installation in Zone 0

When installed in a Zone 0 potentially explosive atmosphere, the indicator shall be installed such that even in the event of rare incidents, an ignition source due to impact or friction between the aluminium enclosure at the rear of the instrument mounting panel and iron/steel is excluded.

When connected to an IECEx certified system the BA448CF-P may be installed in:

- Zone 0 explosive gas air mixture continuously present.
Note: Special conditions for safe use apply see above.
- Zone 1 explosive gas air mixture likely to occur in normal operation.
- Zone 2 explosive gas air mixture not likely to occur, and if it does will only exist for a short time.

Be used with gases in groups:

- Group A propane
- Group B ethylene
- Group C hydrogen

Having a temperature classification of:

- T1 450°C
- T2 300°C
- T3 200°C
- T4 135°C

At an ambient temperature between -40 and

+70°C.

Note: the guaranteed operating temperature range of the BA418C Fieldbus Indicator is -20 to +70°C

The IECEx safety parameters are identical to the ATEX parameters and, like the ATEX certification, confirm that the BA448CF-P complies with the FISCO Field Device requirements specified in IEC60079-27.

The IECEx certificate may be downloaded from www.beka.co.uk, www.iecex.com or requested from the BEKA sales office.

A2.2 Installation

The BA448CF-P IECEx and ATEX certifications have identical intrinsic safety parameters and installation requirements. The ATEX system design requirements described in section 4 of this manual may therefore be used for IECEx installations, but the local code of practice should always be consulted.