

# BA386

## Intrinsically safe LED beacon

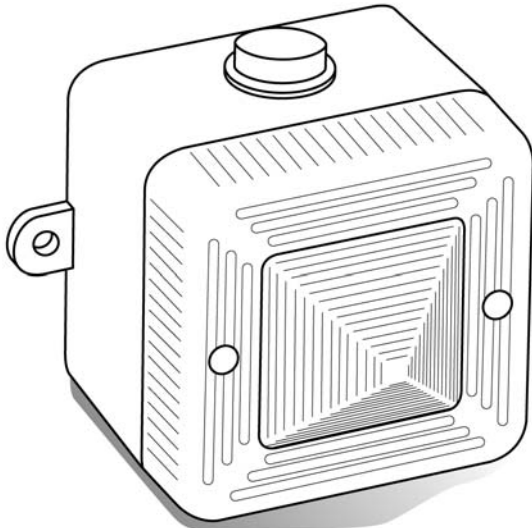

The BA386C beacon is CE marked to show compliance with the European Explosive Atmospheres Directive 94/9/EC and the European EMC Directive 2004/108/EC

### 1. INTRODUCTION

The BA386 is an ATEX certified intrinsically safe beacon which will produce a visual warning in a hazardous area. Red, amber, green, blue and white output models are available.

The BA386 beacon has been designed and certified to work alone or in conjunction with a BEKA intrinsically safe sounder, enabling an intrinsically safe combined audio and visual alarm to be constructed. The BA386 beacon also contains an alarm accept facility which allows an operator to silence the sounder for a predetermined time while leaving the beacon flashing at twice its normal rate.

The BA386 not only performs all the functions of a traditional intrinsically safe xenon beacon, but it has a coloured output and the ability to power a sounder.

### 2. DESCRIPTION

Fig 1 shows a simplified block diagram of a BA386 beacon. The device will start to flash when power is applied to terminals 1 and 2. Terminals 3 & 4 are for the connection of an optional BR385, BR381 or BA385 sounder, which will operate immediately power is applied to the beacon. The sounder may be silenced for a predetermined time by momentarily connecting terminals 5 & 6 together. The silence time may be adjusted between 1 and 30 minutes by a potentiometer inside the beacon. When used alone, i.e. without a sounder connected, two flash frequencies may be selected. With terminals 5 and 6 disconnected the beacon will produce two flashes in quick succession once per second. The flash frequency can be doubled by permanently connecting terminals 5 and 6 together.

When used with a sounder, the beacon produces two flashes in quick succession once per second. When the sounder is silenced the flash frequency is automatically doubled.

### 3. SUPPLY VOLTAGE

The BA386 beacon has been designed to operate in a hazardous area via a Zener barrier or galvanic isolator. The beacon may be tested or used in safe areas without a Zener barrier or galvanic isolator, but at supply voltages above 16V the internal current limit will function and the brightness may be reduced. The beacon should not be continuously operated without a barrier or isolator with a supply voltage greater than 16V.

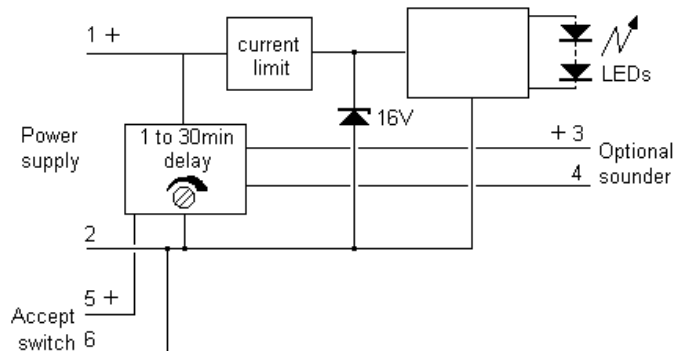

Fig 1 Simplified block diagram

### 4. INTRINSIC SAFETY CERTIFICATION

#### 4.1 ATEX certificate

The BA386 beacon has been issued with EC-Type Examination Certificate number ITS02ATEX2006 by Notified Body Intertek Testing Services (ITS) confirming compliance with the European ATEX Directive 94/9/EC for Group II, Category 1G, gas atmospheres, EEx ia IIC T4. The instrument bears the Community Mark and, subject to local codes of practice, may be installed in any of the European Economic Area (EEA) member countries. i.e. Austria; Belgium; Cyprus; Czech Republic; Denmark; Estonia; Finland; France; Germany; Greece; Hungary; Ireland; Italy; Latvia; Lithuania; Luxembourg; Malta; Netherlands; Poland; Portugal; Slovak Republic; Slovenia; Spain; Sweden; United Kingdom; Iceland; Liechtenstein and Norway. ATEX certificates are also accepted in Switzerland.

This instruction sheet describes installations which conform with BS EN60079:Part14 Electrical Installation in Hazardous Areas. When designing systems for installation outside the UK, the local Code of Practice should be consulted.

#### 4.2 Zones, Gas Groups and T rating

The BA386 LED beacon has been certified EEx ia IIC T4. When connected to an approved system it may be installed in:

Zone 0	explosive gas air mixture continuously present.
Zone 1	explosive gas air mixture likely to occur in normal operation.
Zone 2	explosive gas air mixture not likely to occur, and if it does, it will only exist for a short time.

Be used with gases in groups:

Group A	propane
Group B	ethylene
Group C	hydrogen

Having a temperature classification of:

T1	450°C
T2	300°C
T3	200°C
T4	135°C

Although certified intrinsically safe at ambient temperatures between -40 and +60°C the guaranteed operating temperature range of the beacon is -20 to +60°C.

### 4.3 Certification label information

The certification label is fitted to the side of the beacon. It shows the model number, ATEX certification information and BEKA associates address. The year of manufacture and the beacon serial number are shown on a separate label within the enclosure.



### 4.4 Terminals 1 & 2 - power supply

Power is supplied to the beacon via terminals 1 & 2 which have maximum input safety parameters of:

U <sub>i</sub>	=	28V
I <sub>i</sub>	=	110mA dc
P <sub>i</sub>	=	0.8W

BA386 beacons may be powered from any Zener barrier or galvanic isolator certified by an EC Approved Body with output parameters within these limits.

The equivalent internal capacitance and inductance C<sub>i</sub> and L<sub>i</sub> at terminal 1 & 2 of the beacon are both zero, the maximum permitted cable parameters are therefore defined by the certificate for the barrier or isolator powering the beacon.

### 4.5 Terminals 3 & 4 - connection for optional sounder

These terminals have the same maximum output safety parameters as the Zener barrier or isolator powering the beacon, i.e. if the BA386 beacon is being powered by a 28V, 93mA, 660mW Zener barrier, these terminals will have safety parameters of:

U <sub>o</sub>	=	28V dc
I <sub>o</sub>	=	93mA dc
P <sub>o</sub>	=	0.66W

Any BEKA intrinsically safe sounder may be connected to these terminals providing the intrinsically safe input parameters of the sounder are equal to, or greater than the output parameters of the barrier or isolator powering the BA386 beacon.

The input safety parameters for BEKA sounders are:

Sounder	Input parameters		
BA385-IIB and BA385-IIC	28V	110mA	0.8W
BR381 and BR385	28V	93mA	0.66W

If the beacon and sounder are mounted apart, for intrinsic safety assessment the capacitance and inductance of the interconnecting cable should be added to that of the cable connecting the barrier or isolator to the beacon. See section 4.4.

### 4.6 Terminals 5 & 6 - accept switch

The output safety parameters of these terminals are:

U <sub>o</sub>	=	16.8V
I <sub>o</sub>	=	1.6mA
P <sub>o</sub>	=	7mW

They may be connected to any mechanically operated switch in the same hazardous area as the beacon providing the switch has IP20 protection and can withstand a 500V rms insulation test to earth for 1 minute.

### 4.7 System certificates

Four System Certificates of Conformity provide guidance on selecting suitable Zener barriers & galvanic isolators when the beacon is used alone or with a BA385 sounder.

ITS Ex02E2007	BA386 use with galvanic isolators in IIC
ITS Ex02E2008	BA386 use with Zener barriers in IIC
ITS Ex02E2011	BA386 use with galvanic isolators in IIB
ITS Ex02E2012	BA386 use with Zener barriers in IIB

These certificates, which are not part of the ATEX certification, include the connection of an optional BA385 sounder and permit up to three BA386 beacons to be connected in parallel. Parallel connection of beacons will significantly reduce the brightness of each device. Sounders should not be powered from beacons connected in parallel.

## 5. INSTALLATION

In addition to the certification requirements shown in section 4 the environmental conditions must be within the limits shown on the product specification. The beacon enclosure provides IP66 protection and is suitable for installation in a sheltered exterior location if an appropriate sealed cable entry is used. Please contact BEKA associates if high vibration is anticipated.

### 5.1 Mounting

The BA386 beacon may be secured to any flat surface using the two 6mm diameter fixing holes. The lens should be aimed towards the area where maximum visibility is required.

### 5.2 Installation procedure

- Remove the beacon lens by unscrewing the two captive 'A' screws and pull the lens away from the back box.
- Fit an IP66 M20 cable gland or conduit entry into one of the holes in the enclosure. Secure the back box to a vertical surface using the 6mm diameter holes in the two fixing lugs.

Alternatively, the BA386 beacon may be mounted directly onto a BA385 sounder enclosure and secured using a joining kit which is available from BEKA associates.

- Finally connect the field wiring to the removable terminals, replace the lens and tighten the two 'A' screws.

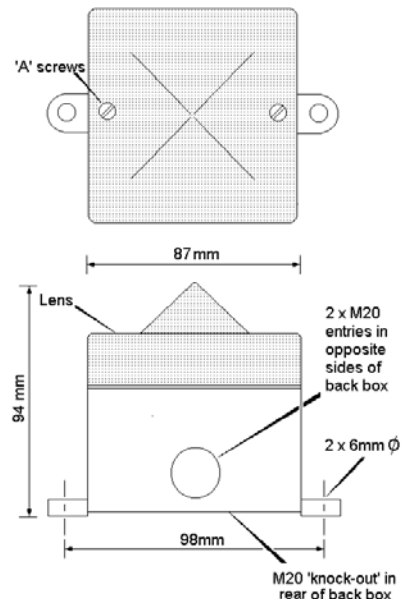
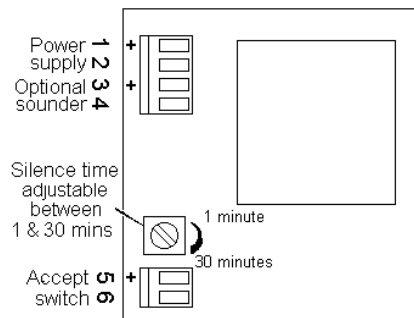

Fig 2 BA386



When the beacon is used alone i.e. without a sounder, terminals 5 & 6 should be connected together

Fig 3 Location of field terminals and controls.

**6. ELECTRICAL SYSTEM DESIGN FOR INSTALLATION IN HAZARDOUS AREAS USING ZENER BARRIERS**

**6.1 Stand alone operation**

If the beacon is controlled by a switch in the positive supply, or the power supply is being turned on and off, only a single channel Zener barrier is required as shown in Fig 4. This circuit may also be used if the beacon is being controlled by a mechanically activated switch on the hazardous area side of the barrier. The power supply voltage should be between 20V and the maximum working voltage of the barrier. The circuit will continue to work at lower voltages, but the beacon brilliance will be reduced.

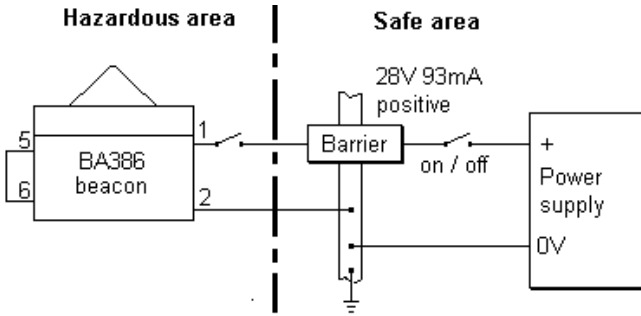

Fig 4 Using a single channel barrier.

If the beacon control switch is in the negative wire and the power supply 0V is earthed, the circuit shown in Fig 5 may be used. For simplicity the two barriers may be combined into one package. The power supply voltage should be between 21V and the maximum working voltage of the 28V barrier. The circuit will continue to work at lower voltages, but the beacon brilliance will be reduced.

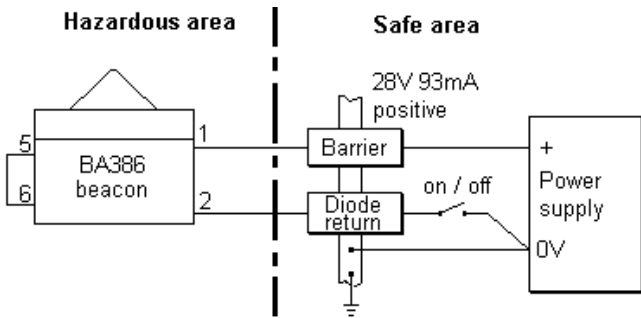

Fig 5 Single stage alarm using two channel barrier.

**6.2 Use with a BEKA intrinsically safe sounder**

The very low current consumption of the BA386 beacon allows it and a BEKA intrinsically safe sounder to be powered from a common Zener barrier as shown in Fig 6. This reduces the sounder output by about 2dBA.

The BA386 beacon contains an adjustable timer activated by a pair of external contacts which will silence the sounder for up to 30 minutes, but leave the beacon flashing at twice its normal frequency. The sounder silence time is set by a potentiometer inside the beacon as shown in Fig 3. An operator may therefore silence the audible alarm but be continuously reminded of the alarm condition by the beacon. If the alarm is not cleared within the silence time, the sounder will be reactivated. If the alarm is cleared during the silence time the beacon will stop flashing, but the beacon and the sounder will both be re-activated if the alarm recurs.

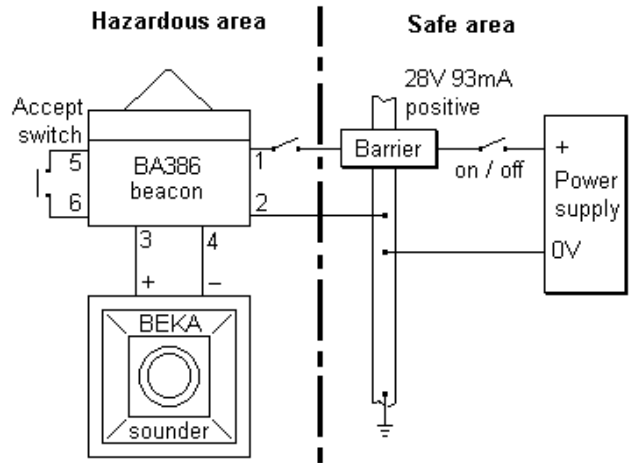

Fig 6 Combined beacon and sounder with alarm accept switch

The accept push-button may be any mechanically operated IP20 switch located within the same hazardous area as the beacon, see section 4.6.

The power supply voltage must be between 21V and the maximum working voltage of the 28V barrier.

**7. ELECTRICAL SYSTEM DESIGN FOR INSTALLATION IN HAZARDOUS AREAS USING GALVANIC ISOLATORS.**

Although more expensive than Zener barriers, galvanic isolators are easier to install as they do not require a high integrity earth connection. Any certified device with output safety parameters below the maximum input safety parameters of the BA386 beacon may be used – See section 4.4.

**7.1 Stand alone operation**

Fig 7 shows the basic circuit that is used for all stand alone applications. The control arrangement will vary depending upon the isolator chosen. The galvanic isolator must be able to supply an output of 25mA at about 16V. This circuit may also be used if the beacon is controlled by a mechanically activated switch on the hazardous area side of the isolator.

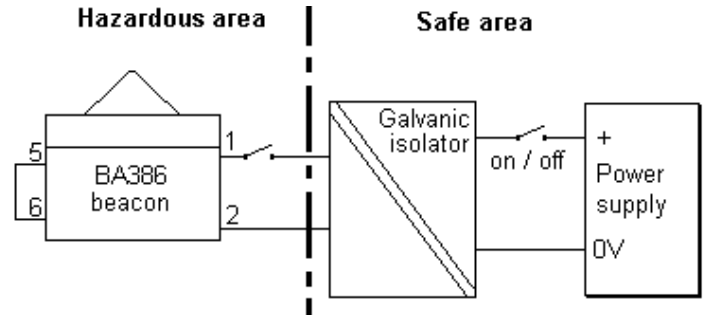

Fig 7 Basic circuit for use with a galvanic isolator.

**7.2 Use with a BEKA intrinsically safe sounder**

The very low current consumption of the BA386 beacon allows it and a BEKA intrinsically safe sounder to be powered from a common galvanic isolator as shown in Fig 8. This reduces the sounder output by about 2dBA.

The BA386 beacon contains an adjustable timer activated by a pair of external contacts which will silence the sounder for up to 30 minutes, but leave the beacon flashing at twice its normal frequency. The sounder silence time is set by a potentiometer inside the beacon as shown in Fig 3. An operator may therefore silence the audible alarm but be continuously reminded of the alarm condition by the beacon. If the alarm is not cleared within the silence time, the sounder will be reactivated. If the alarm is cleared during the silence time the beacon will stop flashing, but the beacon and the sounder will both be re-activated if the alarm recurs. The accept push-button may be any mechanically operated IP20 switch within the hazardous area, see section 4.6.

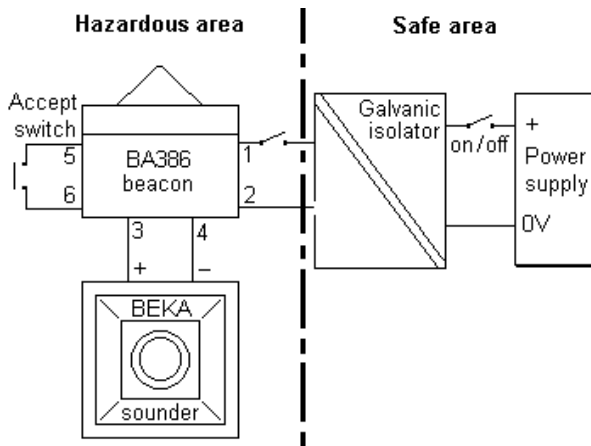

Fig 8 Combined beacon and sounder with alarm accept switch

The chosen galvanic isolator must be able to supply an output of 40mA at about 11V.

## 9. ACCESSORIES

### 9.1 Tag number

The BA386 beacon can be supplied identified by a tag number thermally printed on a self adhesive label.

### 9.2 Beacon to sounder joining kit

Comprises an M20 plastic conduit coupler and gasket enabling the beacon to be mounted onto a BR385 or BA385 sounder. This kit is supplied free of charge when a beacon and sounder are purchased at the same time.

## 10. MAINTENANCE

The beacon should be regularly inspected to ensure that it has not been damaged. Frequency of inspection depends upon environmental conditions, but initially we recommend that this should be done annually.

**No attempt should be made to repair a faulty BA386 beacon. Suspect beacons must be returned to BEKA associates or to your local agent for repair.**

## 11. GUARANTEE

Beacons which fail within the guarantee period should be returned to BEKA associates or our local agent. It is helpful if a brief description of the fault symptoms is provided.

## 12. CUSTOMER COMMENTS

BEKA associates are always pleased to receive comments from customers about our products and services. All communications are acknowledged and whenever possible, suggestions are implemented.

## APPENDIX 1 Installation in USA

### A1.1 Factory Mutual Approval

The BA386 LED beacon has been Factory Mutual approved intrinsically safe for use in Class I, Divisions 1 and 2; Gas Groups A, B, C and D. It has also been approved nonincendive for use in Class I, Division 2, Gas Groups A, B, C and D. See FM file 3014996.

When used alone or with a BA385-IIC intrinsically safe sounder, the BA386 installation must comply with the BEKA associates Control Drawing CI386-12. When used with the louder BA385-IIB intrinsically safe sounder in gas groups C and D, the installation must comply with Control Drawing CI386-13.

At present the BA386 FM intrinsic safety approval does not permit a BEKA BR381 or BR385 sounder to be connected to the beacon.

Copies of the FM Control Drawings are available from BEKA associates and:

Exloc Instruments, Inc.  
19006 Crossroad Parkway  
Culpeper, VA 22701  
USA

Tel: 540 428 3088  
Fax: 540 428 3028  
e-mail: info@exloc.com

All the intrinsically safe circuits shown in this instruction sheet may be used for installations in the USA, providing the Zener barriers and galvanic isolators are Factory Mutual approved and comply with the specified entity parameters. Installations must also comply with the appropriate Control Drawing, ANSI/ISA RP12.6 and the National Electrical Code ANSI/NFPA70

### A1.2 intrinsic Safety Approval

The BA386 beacon has been evaluated under the entity concept. Terminals 1 & 2 of the beacon may be connected to any intrinsically safe circuit having output parameters equal to or less than:

$$\begin{aligned} V_{oc}, V_t &= 32V \\ I_{sc}, I_t &= 110mA \\ P_o &= 0.8W \end{aligned}$$

The equivalent capacitance and inductance at terminals 1 & 2 are:

$$\begin{aligned} C_i &= 30pF \\ L_i &= 0 \end{aligned}$$

$C_i$  must therefore be subtracted from the maximum permissible cable capacitance specified for the Zener barrier or galvanic isolator powering the beacon.

The BA386 beacon has a T4 rating and may be used at ambient temperatures between  $-20$  and  $+60^\circ\text{C}$ .

**Note:** The BA386 beacon is not approved for use with Class II and III dusts and fibers.

### A1.3 Terminals 3 & 4 - connection of optional sounder

One FM approved BA385-IIC intrinsically safe sounder (FM file 3001558) for gas groups A, B, C & D, or the louder BA385-IIB sounder for gas groups C & D, may be connected to terminals 3 & 4 of the beacon.

### A1.4 Terminals 5 & 6 - accept switch

When used with a sounder the alarm accept terminals may be connected to any mechanically operated switch that complies with the requirements for *simple apparatus* e.g. a push-button switch having IP20 protection and able to withstand a 500V rms insulation test to ground for one minute.

### A1.5 Nonincendive Approval

The BA386 is also Factory Mutual approved nonincendive for Class I, Division 2 locations. This allows it to be installed in Division 2 without a Zener barrier or galvanic isolator when powered from a Factory Mutual approved associated apparatus having nonincendive output parameters equal to or less than:

$$\begin{aligned} V_{oc} &= 32V \\ I_{sct} &= 110mA \end{aligned}$$

PLTC or ITC cables may also be used as a suitable wiring method in Division 2 without Zener barriers or galvanic isolators, providing the BA386 beacon is fitted with a Killark CGUAXM20 cable entry gland. Installation is restricted to one BA386 beacon plus one BA385 sounder. An accept switch may not be used with this type of installation.

At present the BA386 FM nonincendive approval does not permit a BEKA BR381 or BR385 sounder to be connected to the beacon. **Issue 5 Nov 2010**