

BA538C

Externally powered pulse input panel mounting rate totaliser

issue 11

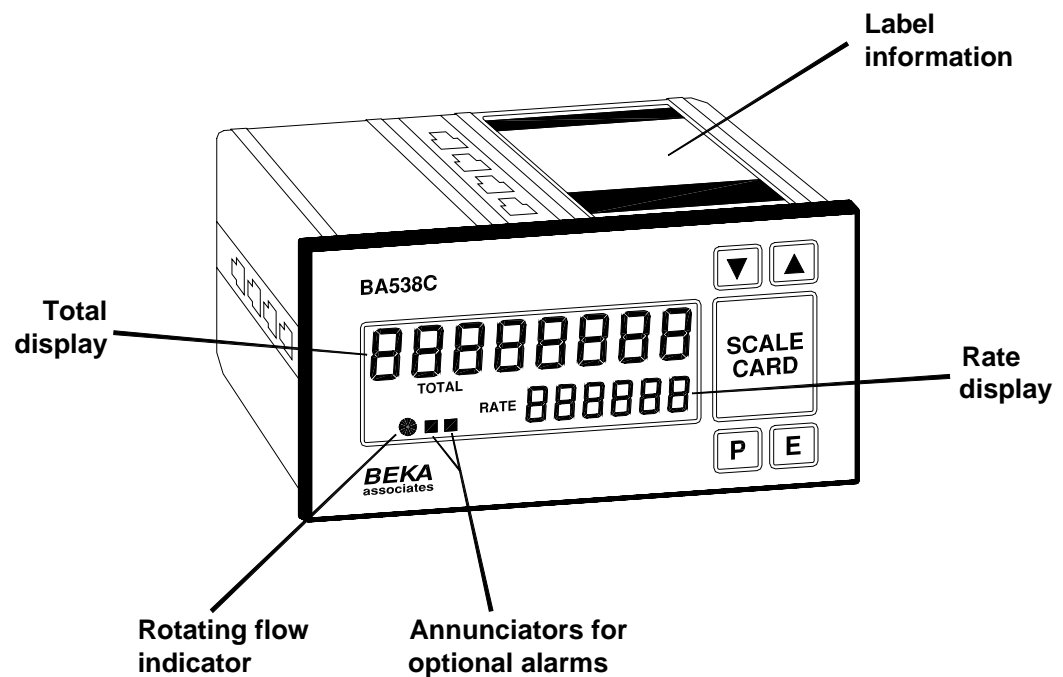

CONTENTS

1. Description

2. Operation

- 2.1 Initialisation
- 2.2 Controls
- 2.3 Displays

3. System Design

- 3.1 Flow transmitter loops
- 3.2 Power supply
- 3.3 Pulse input
- 3.4 Remote reset

4. Installation

- 4.1 Location
- 4.2 Installation procedure
- 4.3 EMC

5. Programming and Calibration

- 5.1 Calibration structure
- 5.2 Accessing programme functions
- 5.3 Summary of programmable functions.
- 5.4 Display update interval
- 5.5 Type of input
- 5.6 Position of the decimal points
- 5.7 Lower display
- 5.8 Rate scale factor
- 5.9 Timebase
- 5.10 Rate filter
- 5.11 Total scale factor
- 5.12 Clip-off
- 5.13 Local reset
- 5.14 Resetting grand total
- 5.15 Security code

6. Calibration Example

- 6.1 Calibration procedure

7. Maintenance

- 7.1 Fault finding during commissioning
- 7.2 Fault finding after commissioning
- 7.3 Servicing
- 7.4 Routine maintenance
- 7.5 Guarantee
- 7.6 Customer comments

8. Accessories

- 8.1 Scale card
- 8.2 Tag number
- 8.3 Alarms
 - 8.3.1 Solid state output
 - 8.3.2 Programming and adjustment
 - 8.3.3 Alarm enable
 - 8.3.4 Type of alarm
 - 8.3.5 Setpoint adjustment
 - 8.3.6 Alarm function
 - 8.3.7 Alarm output status
 - 8.3.8 Hysteresis
 - 8.3.9 Alarm delay
 - 8.3.10 Alarm silence time
 - 8.3.11 Access setpoint
 - 8.3.12 Adjusting alarm setpoints from display mode.
- 8.4 Display backlight
- 8.5 Pulse Output
- 8.6 4/20mA output
 - 8.6.1 Programming & adjustment

9. Index

The BA538C is CE marked to show compliance with the
European EMC Directive 2004/108/EC

1. DESCRIPTION

The BA538C is an externally powered pulse input rate totaliser primarily intended for use with flowmeters. The instrument simultaneously displays the rate of flow and the total flow in engineering units on two separate displays.

Housed in a robust 72 x 144 panel mounting DIN enclosure, the BA538C has an IP65 front panel and is supplied with a gasket to seal the joint between the instrument and the panel.

2. OPERATION

Fig 1 shows a simplified block diagram of a BA538C. The instrument accepts pulses from a single source and after scaling displays the total number of pulses received and their rate on separate displays. When connected to a pulse output flowmeter the BA538C will provide an accurate display of total flow and the rate of flow.

The BA538C has two sets of input terminals for connection to high or low level voltage pulses, a switch contact, an open collector output or to a two wire proximity detector. The instrument may therefore be used with almost any pulse output flowmeter. The total display may be reset to zero by a remote switch contact or from the front push-buttons.

Optional accessories enable the flow rate to be transmitted to other equipment as an isolated 4/20mA analogue signal and the total flow to be transmitted as a pulse signal. Optional alarms, which may be programmed to function on the rate or total displays, further extend the instrument's applications.

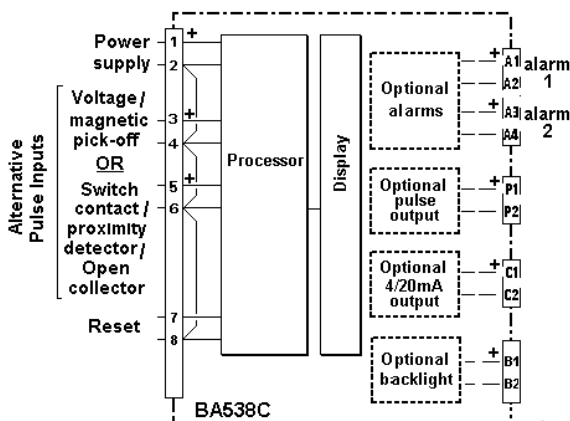

Fig 1 Simplified block diagram of BA538C

2.1 Initialisation

Each time power is applied to the instrument initialisation is performed. After a short delay the following display sequence occurs:

All segments of the display are activated for about 2 seconds.

The product firmware number and the version number are displayed for about 2 seconds.

Rate display and totaliser start to function using calibration information stored in the instrument's permanent memory.

2.2 Controls

The BA538C is controlled and calibrated via four front panel push-button switches. In the display mode i.e. when the instrument is displaying rate and total flow the switch functions are:

Description of Switch Functions

E+ Down While these buttons are pushed the total display will show the least significant eight digits of the grand total, and the grand total annunciator will be activated.

E+ Up While these two buttons are pushed the total display will show the most significant eight digits of the grand total and the grand total annunciator will be activated.

Down +Up Resets the total display to zero when these two push-buttons are operated simultaneously for more than two seconds. Selectable function from programme menu. See section 5.12

Down +P While these buttons are pushed the instrument will display the firmware part number and version number.

Note: When optional alarms are fitted the push-buttons may be programmed to have alternative functions – see section 8.3

2.3 Displays

The BA538C has two digital displays and associated annunciators, plus a flow indicator as shown on page 1.

Rate Display	Shows the flow rate on the smaller six digit display.
Total display	Shows the total flow on the larger eight digit display. Set to zero when local or remote reset switch is operated.
Flow indicator	This disc in the lower left hand corner of the display 'rotates' for two seconds each time an input pulse is received. Therefore when the pulse input frequency exceeds 0.5Hz the disc appears to rotate continuously.
Hold Annunciator	Activated when input frequency is below the clip-off threshold.
Reset Annunciator	Activated when the instrument is being reset.

3. SYSTEM DESIGN

3.1 Flow transmitter loops

The BA538C may be connected to almost any pulse output flowmeter and calibrated to display rate of flow and total flow in the same or different engineering units.

Fig 2 illustrates the basic circuit that is used for all BA538C installations. For simplicity, connections for the optional pulse output, 4/20mA output and backlight are included in section 8 of this manual.

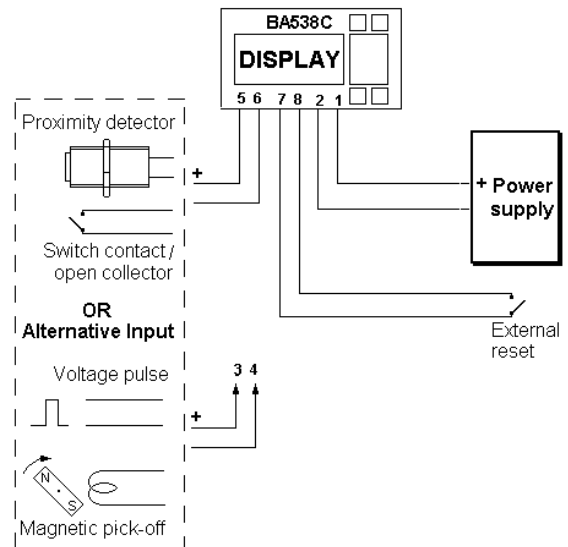

Fig 2 BA538C in flow application

When designing a system it is important to remember that terminals 2, 4, 6 and 8 are interconnected within the BA534D - see Fig 1.

3.2 Power supply

The BA538C may be powered from any dc supply having an output voltage between 10 and 30V. The instrument consumes about 12mA rising to 15mA when a proximity detector input is used.

3.3 Pulse input

As shown in Fig 2, the BA538C will count pulses from a wide variety of transducers enabling it to display the output from almost any flowmeter.

The instrument has one pulse input, but two sets of input terminals enable it to accommodate different types of transducers. Terminals 3 and 4 are for voltage pulse inputs and terminals 5 and 6 are for pulse sources that need powering i.e. proximity detectors, switches and open collectors.

Note: Only one pair of input terminals may be used at a time. i.e pulses can not be counted from terminals 3 & 4 and from terminals 5 & 6 at the same time.

The following table shows the switching thresholds for the various transducers, plus the maximum operating frequency and the input terminal numbers. For reliable counting the input signal must fall below the lower threshold and rise above the upper threshold.

	Switching thresholds		Freq max	Input terminals
	100Ω	1000Ω		
Switch	1.2mA	2.1mA	100Hz	5 & 6
Proximity detector	2kΩ	10kΩ	5 kHz	5 & 6
Open collector	0mV	20mV peak	5kHz	3 & 4
Magnetic pick-off	1.0V	3.0V	5kHz	3 & 4
Voltage pulse				

3.4 Remote reset

The BA538C total display is reset to zero when terminals 7 & 8 are connected together for more than one second. Permanent interconnection of these terminals will stop totalisation and may be used as an inhibit function. There is no practical limit on the distance that the reset switch may be from the totaliser.

Alternatively, the BA538C may be programmed so that the total display is reset to zero when the *Up* and *Down* push-buttons are operated simultaneously for more than two seconds. – see 5.12

4. INSTALLATION

4.1 Location

The BA538C is housed in a robust aluminium enclosure with a polyester membrane front panel surrounded by a Noryl bezel. The front of the instrument provides IP65 protection and a gasket seals the joint between the instrument enclosure and the panel. The instrument may be installed in any panel providing the environmental limits shown in the specification are not exceeded.

Although the front panel of the instrument has IP65 protection, the BA538C is not intended for external mounting. Please refer to BEKA associates if external mounting is required.

Fig 3 shows the overall dimensions of the BA538C and the panel cut-out. To achieve an IP65 seal between the instrument enclosure and the panel the smaller cut-out must be used and the instrument secured with four panel mounting clips.

The BA538C liquid crystal display has maximum contrast when viewed from directly ahead and slightly below the centre line of the instrument. For reflective displays there is little degradation of contrast when viewed from above the centre line, but slight degradation may be noticeable when the instrument is fitted with a backlight.

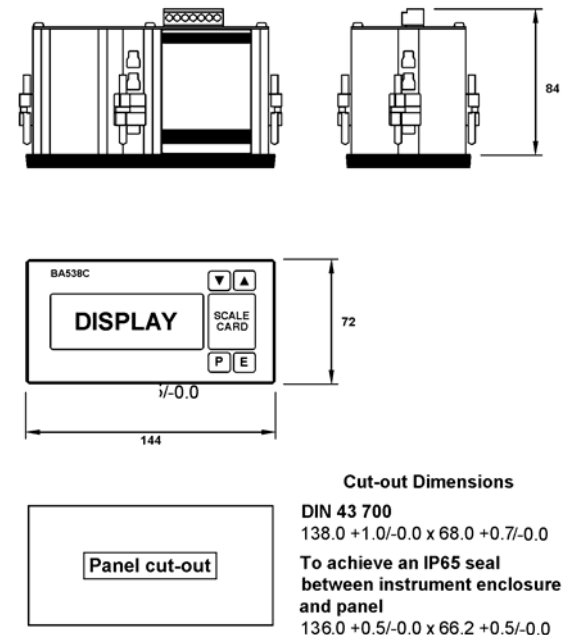

Fig 3 BA538C dimensions

4.2 Installation Procedure

- Insert the BA538C into the instrument panel cut-out from the front of the panel.
- Fix panel mounting clips to opposite sides of the instrument and tighten until the instrument is secure as shown in Fig 4. Four clips are required to achieve an IP65 seal between the instrument enclosure and the panel.
- Connect the panel wiring to the rear terminal block(s) as shown in Fig 4. To simplify installation, the terminals are removable so that panel wiring can be completed before the instrument is installed.

4.3 EMC

The BA538C complies with the requirements of the European EMC Directive 2004/108/EEC. For specified immunity all wiring should be in screened twisted pairs.

To prevent circulating currents, cable screens should only be earthed at one point.

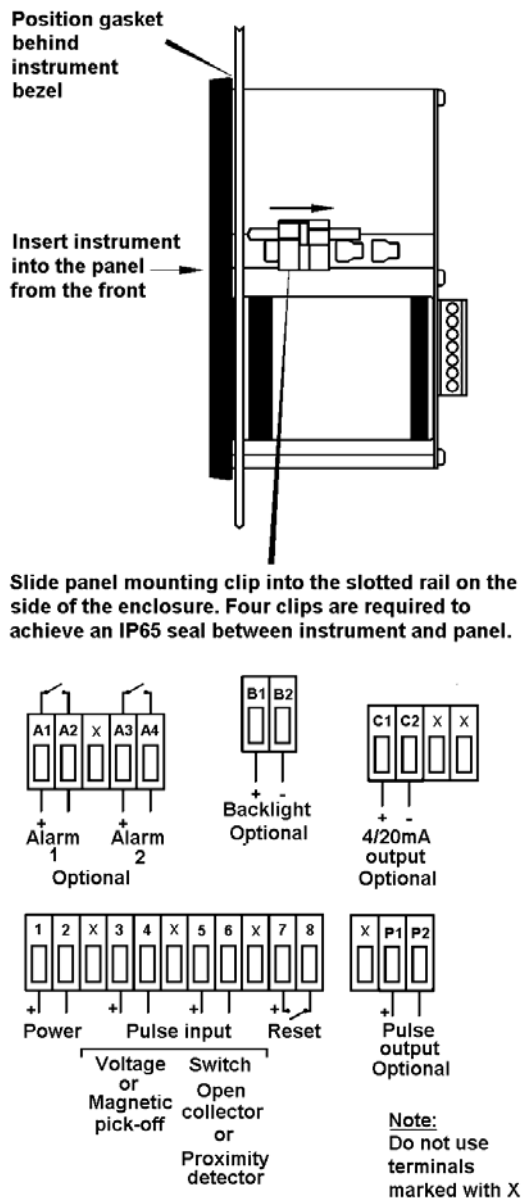

Fig 4 Installation and terminal connections

5. PROGRAMMING & CALIBRATION

The BA538C is programmed and calibrated via four front panel push-buttons. All the programming functions are contained in an easy to use menu that is shown diagrammatically in Fig 6. Each function is summarised in section 5.3 and includes references to more detailed information. Although this simple menu driven system enables most adjustments to be made without repeated reference to this manual, it is recommended that at least the summary of the programmable functions in section 5.3 is read before attempting programming or recalibration.

When the BA538C is fitted with alarms, a pulse output or a 4/20mA output, the basic menu is expanded to include the option(s). Section 8 of this manual explains how to programme these additional functions.

Note: While the instrument is being programmed or calibrated, totalisation continues so that any flow occurring during this time is recorded.

5.1 Calibration structure

Fig 5 shows the BA538C calibration structure. The rate and total display calibration functions are totally independent allowing the displays to have different engineering units.

For the rate display the pulse input is divided by SCALE-r to represent engineering units and multiplied by the timebase t-bASE to calculate and display the rate of flow per second, minute or hour.

Similarly, to calculate the total flow in engineering units the number of input pulses is divided by the total scale factor SCALE-t. Total flow is continuously added to the grand total.

The BA538C displays 'real' decimal points. Moving the position of a decimal point in a scale factor will therefore affect the instrument calibration.

The BA538C updates its total flow calculation twice per second. If the instrument is used for batching applications, this resolution may define the accuracy of the system.

Note: The total and rate displays may be updated less frequently depending upon the display update time selected.

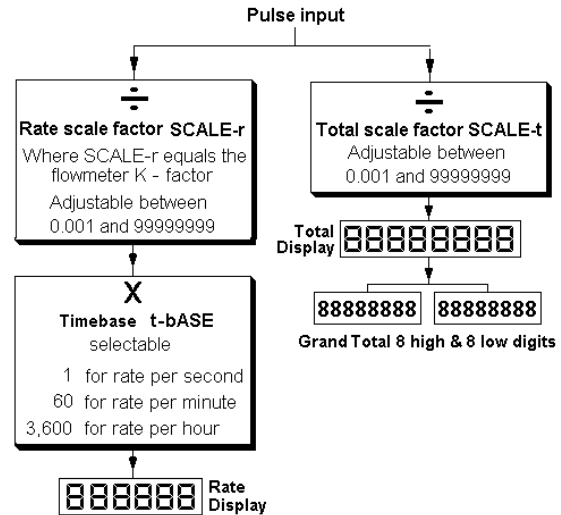

Fig 5 Calibration structure

5.2 Accessing programming functions

Throughout this manual push-buttons are shown in italics e.g. *P* or *Up* push-button, and legends displayed by the instrument are shown within inverted commas e.g. 'CAL' and 'ALr2'.

Access to the programme menu is obtained by operating the *P* and *E* push-buttons simultaneously. If the instrument is not protected by a security code the first parameter 'UPdAtE' will be displayed. If a security code other than the default code 0000 has already been entered, the instrument will display 'COdE'. Press *P* to clear this prompt and enter the security code for the instrument using the *Up* or *Down* push-buttons to adjust each digit, and the *P* push-button to move control to the next digit. If the correct code has been entered pressing *E* will cause the first parameter 'UPdAtE' to be displayed. If an incorrect code is entered, or a push-button is not operated within ten seconds, the instrument will automatically return to the display mode.

Apart from defining the position of the decimal point in the rate display, all programme functions and prompts are shown on the large eight digit display.

Once within the main programme menu the required parameter can be reached by scrolling through the menu using the *Up* and *Down* push-buttons as shown by the programme structure in Fig 6.

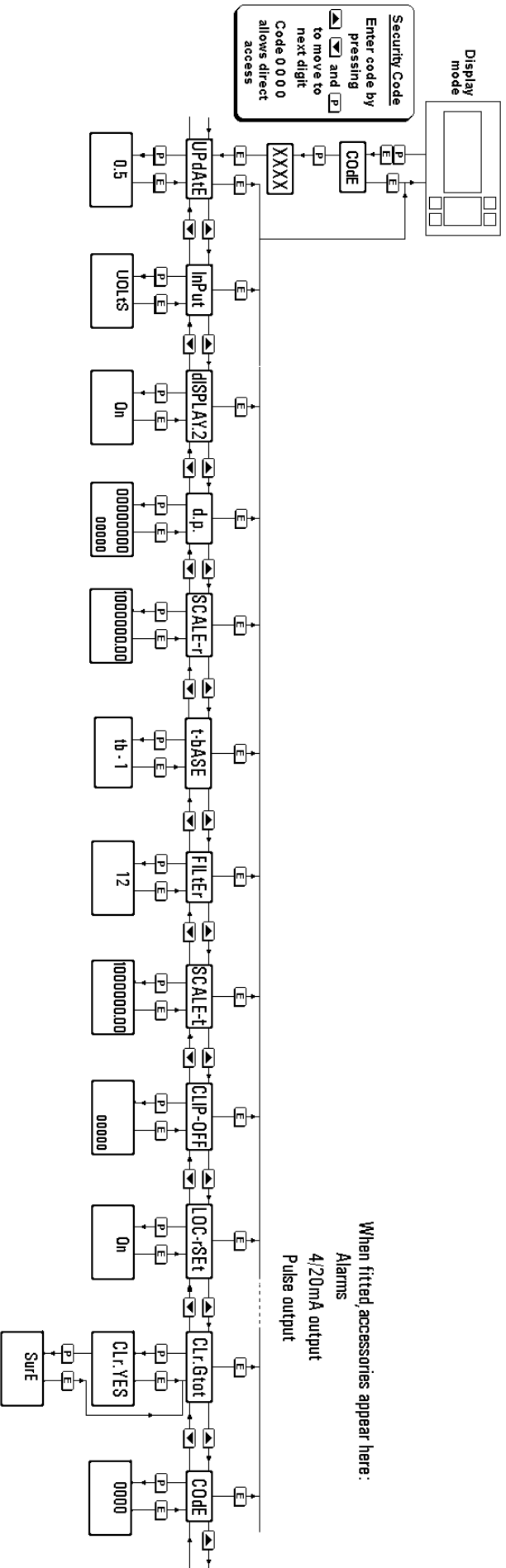

- Display update time**
to select time between display updates
0.5, 1.0, 2.0, 3.0, 4.0 or 5.0 seconds
- Input**
to select type of input
VOLTS for voltage pulse
COIL for magnetic pick-off
Pr.DET for proximity detector
CONTACT for switch contact
OP.COIL for open collector
- Lower display**
to turn the lower display On or OFF
- Decimal point**
to select position of decimal point and [E] to toggle between displays
Press [E] + [E] to interchange rate and total displays
- Rate scale factor (K factor)**
Press [E] or [E] to adjust value and [E] to move to next digit.
Press [E] + [E] to position decimal point
- Timebase**
to select totaliser timebase
lb-1 for flow/sec
lb-60 for flow/min
lb-3600 for flow/hour
- Rate filter**
to adjust value of each digit and [E] to move to other digit.
First digit filter magnitude
Second digit step response
- Total scale factor**
to adjust value and [E] to move to next digit.
Press [E] + [E] to position decimal point
- Clip-off**
to adjust rate to display at which clip-off occurs
- Local reset**
to turn the local reset function On or OFF
When On is selected total display is reset to zero when [E] and [E] are operated simultaneously
- Clear grand total**
to select CL:YES confirmed by entering by SUE using [E] or [E]
to adjust display and [E] to move to next digit
WARNING
Cleared grand total can not be recovered
- Define Security Code**
Enter by pressing [E] or [E] and [E] to move to next digit

Fig 6 Programme Structure

All new BA538C rate totalisers are supplied calibrated as requested at the time of ordering. If calibration information is not supplied, the instrument will be conditioned for an open collector input, with SCALE-r and SCALE-t set to 1 and a timebase of seconds.

5.3 Summary of programmable functions

This section summarises all the programmable functions. When read in conjunction with Fig 6 it provides a quick aid for programming the instrument. If more detail is required, each section contains a reference to a full description of the function.

SUMMARY

<u>Display</u>	<u>Description of function</u>										
'UpdAtE'	<p>Display update time Allows the interval between display updates to be selected. See section 5.4</p>										
'InPut'	<p>Type of input Enables one of five types of input to be selected:</p> <table border="0"> <tr> <td>UOLtS</td> <td>Voltage pulse</td> </tr> <tr> <td>COIL</td> <td>Magnetic pick-off</td> </tr> <tr> <td>Pr.dEt</td> <td>NAMUR proximity detector.</td> </tr> <tr> <td>COntACt</td> <td>Switch contact</td> </tr> <tr> <td>OP.COL</td> <td>Open collector</td> </tr> </table> <p>See section 5.5</p>	UOLtS	Voltage pulse	COIL	Magnetic pick-off	Pr.dEt	NAMUR proximity detector.	COntACt	Switch contact	OP.COL	Open collector
UOLtS	Voltage pulse										
COIL	Magnetic pick-off										
Pr.dEt	NAMUR proximity detector.										
COntACt	Switch contact										
OP.COL	Open collector										
'd.P.'	<p>Decimal points Defines the position of the decimal point in both the rate and total displays and enables the rate and total displays to be interchanged. See section 5.6</p>										
'dISPLAY.2'	<p>Lower display Turns the lower display, which normally shows rate, on or off. See section 5.7</p>										
	<p>'SCALE-r' Rate Scale Factor Defines the arithmetic relationship between the pulse input frequency and the rate display. May be adjusted between 0.001 and 99999999. When used with a flowmeter, SCALE-r should be set to the flowmeter K factor (pulses per unit of measurement) if the display is required in the same flow units as the K factor. See section 5.8</p>										
	<p>'t-bASE' Timebase Selectable multiplier to display flow rate in units per second, per minute or per hour. Select:</p> <table border="0"> <tr> <td>tb-1</td> <td>for flow / second</td> </tr> <tr> <td>tb-60</td> <td>for flow / minute</td> </tr> <tr> <td>tb-3600</td> <td>for flow / hour</td> </tr> </table> <p>See section 5.9</p>	tb-1	for flow / second	tb-60	for flow / minute	tb-3600	for flow / hour				
tb-1	for flow / second										
tb-60	for flow / minute										
tb-3600	for flow / hour										
	<p>'FILtEr' Rate filter Adjustable digital filter to reduce noise on the rate display. Two parameters each adjustable between 0 and 9. See section 5.10</p>										
	<p>'SCALE-t' Total Scale Factor Defines the arithmetic relationship between the number of input pulses and the total display. May be adjusted between 0.001 and 99999999. When used with a flowmeter SCALE-t should be set to the flowmeter K factor (pulses per unit of measurement). See section 5.11</p>										
	<p>'CLIP-OFF' Clip off To prevent the totalisation of very low flow rates, clip-off enables the user to select a flow rate below which totalisation is inhibited. See section 5.12</p>										

Display	Description of function
----------------	--------------------------------

'LOC.rSEt'	Local reset of total display
-------------------	-------------------------------------

When turned 'On' the total display may be reset to zero from the display mode by simultaneously operating the *Up* and *Down* push-buttons for more than two seconds.
See section 5.13

'CLr. Gtot'	Clears grand total
--------------------	---------------------------

This function resets the grand total to zero when 'CLr YES' is selected, and 'SurE' is entered to confirm the instruction.

Note: Once cleared, a grand total can not be recovered.
See section 5.14

'COdE'	Security code
---------------	----------------------

Defines a four digit numeric code which must be entered to gain access to the programmable functions. Default code 0000 disables the security function and allows unrestricted access to all programmable functions.
See section 5.15

'UOLts'	Voltage pulse input Threshold 1V and 3V 5kHz max. Input terminals 3 and 4
----------------	--

'COIL'	Low voltage pulse Threshold 20mV peak 5kHz max. Input terminals 3 and 4
---------------	--

'Pr.dEt'	NAMUR proximity detector Threshold 1.2 and 2.1mA 5kHz max. Input terminals 5 and 6
-----------------	---

'COntACt'	Switch contact Threshold 100 and 1000Ω 100Hz max Input terminals 5 and 6
------------------	---

'OP.COL'	Open collector Threshold 2kΩ and 10kΩ 5kHz max. Input terminals 5 and 6
-----------------	--

When the required type of input has been selected press *E* to return to the main menu.

Note: To count correctly, the input signal must fall below the lower switching threshold and rise above the higher switching threshold.

5.4 Display update interval: 'UpdAtE'

Six different intervals between display updates varying between 0.5 and 5 seconds may be selected. If either the rate or the total displays are likely to change rapidly, a longer interval between updates may simplify reading the instrument display. The selected update interval does not affect the update time of any other instrument function such as the optional 4/20mA output.

To define the update interval select 'UpdAtE' from the main menu and press *P* to reveal the current time. Pressing the *Up* or *Down* button will scroll through the six times. When the required interval has been selected press *E* to return to the main menu.

5.5 Type of input: 'InPut'

The BA538C may be programmed to accept pulse inputs from a wide variety of sensors. To define an input type select 'InPut' from the menu and press *P* which will reveal the current input type. Pressing *Up* or *Down* will scroll through the five options:

5.6 Position of the decimal points: 'd.P.'

The rate display can have up to six digits and the decimal point may be positioned between any of them, or omitted. Similarly, the total display has eight digits and the decimal point may be positioned between any of them, or may be omitted.

To adjust the position of either decimal point select 'd.P.' from the main menu and press *P*. This will activate both displays with one digit plus the following decimal point of the total display flashing. If only the least significant digit is flashing, this indicates that the decimal point is omitted.

The position of the decimal point can be moved by pressing the *Up* or *Down* push-button. Operating the *P* push-button will toggle control between the two displays. When both decimal points have been correctly positioned press *E* to return to the main menu.

If the application requires flow rate to be the primary display i.e. shown on the large display, the d.P. function enables the rate and total displays to be interchanged. The rate display will continue to have six digits but the total display will

be reduced from eight to six digits. The rate and total annunciators will also be interchanged. Pressing the *Up* and *Down* buttons simultaneously will interchange the displays.

Note: Both decimal points must be repositioned after the displays have been interchanged.

5.7 Lower display: 'DISPLAY.2'

This function turns the lower display on or off. When turned off, the BA538C will only have one eight digit display which may be programmed to show total flow or rate of flow.

5.8 Rate scale factor: 'SCALE-r'

Together with the instrument timebase, this function defines the arithmetic relationship between the pulse input frequency and the rate display. When used with a flowmeter SCALE-r should be set to the K-factor of the flowmeter i.e. the number of pulses the flowmeter produces for a unit of flow. e.g. 45.6 pulses per litre. See section 6 for a worked example.

SCALE-r is a dividing factor that may be adjusted between 0.001 and 99999999.

To check or change the total scale factor select 'SCALE-r' from the main menu and press *P* to reveal the existing setting, one digit will be flashing. The value of the flashing digit can be changed by pressing the *Up* or *Down* buttons. When this digit is correct pressing *P* will transfer control to the next digit.

To position the decimal point in the rate scale factor, move the flashing digit to the left hand side of the required decimal point position and simultaneously press the *Up* and *Down* buttons.

When the required rate scale factor has been entered, press *E* to store the number and return to the main menu.

5.9 Timebase: 't-bASE'

The timebase multiplies the rate display by 1, 60 or 3,600 depending upon whether the BA538C is required to display rate per second, per minute or per hour. See Fig 5.

To check or change the timebase, select 't-bASE' from the main menu and press *P* which will reveal the current setting. Pressing the *Up* or *Down* button will index through the three options:

tb-1	for flow / second
tb-60	for flow / minute
tb-3600	for flow / hour

Select the required multiplier and press *E* to return to the main menu.

5.10 Rate filter: 'FILtEr'

This digital filter has two independent adjustable parameters enabling the rate display frequency response to be tailored for optimum performance.

The filter parameters are controlled by a two digit number. The first digit defines the amount of filtering applied to the display as shown below.

First digit	Filter time constant seconds
0X	0
1X	1.3
2X	4.3
3X	6.5
4X	8.7
5X	11.3
6X	15.7
7X	20.9
8X	25.2
9X	31.5

The second digit defines the deviation from the displayed rate at which the filter will be overridden and the rate display will move rapidly to the new value.

Second digit	Magnitude of step change which will produce a rapid response
X0	Off
X1	1%
X2	2%
X3	4%
X4	8%
X5	12%
X6	16%
X7	24%
X8	32%
X9	64%

By careful adjustment of the two parameters a stable display with an acceptable step input response can be obtained for most applications.

During commissioning it is recommended that initially the second digit is set to 0 (off) and the first digit is adjusted to provide acceptable rate display stability. The second digit should then be increased until the selected step size is greater than the noise on the display signal, at which setting the rate display will again become stable. These will be the optimum filter parameters for acceptable rate display stability and a fast response to a large rate signal change.

To check or change the filter select 'FILtEr' from the main menu and press *P* to reveal the current settings. Pressing the *Up* or *Down* button will change the flashing digit and *P* will transfer control to the second digit. While making adjustments the filtered rate display is shown on the lower display so that stability can be assessed. When set as required, press the *E* button to enter the revised parameters and return to the main menu.

5.11 Total scale factor: 'SCALE-t'

This factor defines the arithmetic relationship between the number of input pulses and the total display. SCALE-t is a dividing factor that may be adjusted between 0.001 and 99999999. See Fig 5.

When used with a flowmeter SCALE-t should be set to the K-factor of the flowmeter i.e. the number of pulses the flowmeter produces for a unit of flow. If the BA538C total display is required in units different from those in which the flowmeter K factor is specified, a conversion factor will be required.

e.g. If the flowmeter has a K factor of 45.6 pulses per litre and the BA538C total display is required in units of 1,000 gallons, then SCALE-t should be set to number of pulses produced by the flowmeter per 1,000 gallons:

$$45.6 \times 4.54609 \times 1000$$

$$207,301.7 \text{ pulses per } 1000 \text{ gallons}$$

(there are 4.54609 litres in a UK gallon)

To check or change the total scale factor select 'SCALE-t' from the main menu and press *P* to reveal the existing setting, one digit will be flashing. The value of the flashing digit can be changed by pressing the *Up* or *Down* buttons. When this digit is correct pressing *P* will transfer control to the next digit.

To position the decimal point in the scaling factor, move the flashing digit to the left hand side of the required decimal point position and simultaneously press the *Up* and *Down* buttons.

When the required total scale factor has been entered, press *E* to store the number and return to the main menu.

5.12 Clip-off: 'CLIP-OFF'

To prevent totalisation of very low flow rates that over long periods may result in significant totalisation errors, the BA538C may be programmed to stop totalising when the flow rate falls below an adjustable threshold.

To check or change the clip-off threshold select 'CLIP-OFF' from the main menu and press *P* which will reveal the current setting. The threshold is shown in the units already selected for the flow rate display. One digit will be flashing. The value of the flashing digit may be changed by pressing the *Up* or *Down* buttons. When this digit is correct pressing *P* will transfer control to the next digit. When clip-off is set as required, press the *E* button to enter the revised figure and return to the main programme menu.

If the flow rate falls below the entered threshold, the rate display will show zero flow, totalisation will stop and the HOLD annunciator will be activated. The flow indicator will rotate for 2 seconds each time an input pulse is received i.e. at input frequencies above 0.5Hz it will appear to rotate continuously.

Note: When the rate scale factor SCALE-r, the timebase t-bASE, or the position of the rate display decimal point are changed, clip-off will automatically be reset to zero. If required, a new clip-off threshold may then be entered.

5.13 Local reset of total display: 'LOC. rSEt'

When activated this function enables the operator to reset the BA538C total display to zero in the display mode by operating the *Up* and *Down* push-buttons simultaneously for more than two seconds. To check the status of the local reset function select 'LOC.rSEt' from the menu and press *P* which will reveal if the function is 'On' or 'OFF'. If necessary press the *Up* or *Down* button to change the setting, followed by the *E* button to return to the main menu.

The total display may also be reset to zero remotely by connecting terminals 7 and 8 together. See section 3.4 of this manual.

5.14 Resetting grand total: 'CLr. Gtot'

The grand total is a separate sixteen digit counter which duplicates the total display but is not zeroed when the total display is reset to zero. The grand total may be viewed in the display mode in two eight digit sections as described in section 2.2 of this manual.

The grand total counter can only be reset to zero from the 'CLr. Gtot' function in the main programme menu. To zero the grand total counter select 'CLr. Gtot' and press *P* which will cause the instrument to display 'CLr. no' with 'no' flashing. Continuously press the *Up* or *Down* push-buttons until 'CLr. YES' is displayed and then press *P* which will result in a 'CLr 0000' prompt with one digit flashing. Using the *Up* and *Down* buttons and the *P* button to move to the next digit, confirm the request by entering the password 'SurE'. Note 'S' is entered as '5'. Pressing *E* will then reset the grand total counter to zero and return the instrument to the 'CLr. Gtot' prompt in the main menu.

WARNING

After resetting the grand total counter to zero the old grand total can not be recovered.

5.15 Security code: 'CodE'

The calibration and conditioning of the instrument may be protected by a four digit security code which must be entered before access to the programme menu is granted. New instruments are programmed with the default security code 0000 which allows unrestricted access to all programming functions without entering a security code.

To enter a new security code select 'COdE' from the menu and press *P* which will cause the instrument to display the current security code. Each digit of the code can be changed using the *Up* and *Down* push-buttons, and the *P* button to move to the next digit. When the required code has been entered press *E* to return to the main menu. The revised security code will be activated when the indicator is returned to the display mode.

If the security code is lost, access to the programmable functions can be obtained by moving the internal security link to the override position. The original security code can then be viewed by selecting 'CodE' from the main menu and pressing *P*.

To gain access to the security code link, remove the instrument terminal block(s) by gently pulling. Remove the five screws securing the rear panel and lift off the panel to reveal the link – see Fig 7.

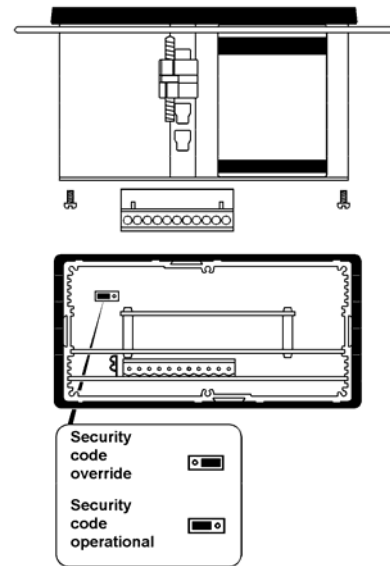

Fig 7 Location of security override link

6. CALIBRATION EXAMPLE

In this example a BA538C rate totaliser is connected to a turbine flowmeter having a K-factor of 1050.0 pulses per litre. The flowmeter has a magnetic pick-off with an output greater than 20mV peak at 5 litres per minute and a usable range of 5 to 60 litres per minute.

The BA538C is required to display rate of flow in litres per hour with a resolution of one litre and total flow in cubic metres with a resolution of 0.01 cubic metres. Totalisation is to stop when the flow rate falls below 300 litres per hour. The display is to be updated twice per second and filtering is required. In this application the operator needs to reset the total display to zero by simultaneously pushing the *Up* and *Down* push-buttons. To prevent tampering the instrument programme menu is to be protected by security code 1209

6.1 Calibration procedure

The BA538C rate totaliser may be calibrated on-site without disconnection from the power supply or from the flowmeter.

Step 1 Enter the programming mode

Put the BA538C in the programming mode by simultaneously pressing *P* and *E*. Assuming a security code has not already been entered the instrument will respond by displaying 'UPdAtE' which is the first function in the main menu. See Fig 6.

Step 2 Select the interval between display updates

With 'UPdAtE' displayed, press *P* to reveal the existing interval between display updates. If this is not as required, press the *Up* or *Down* button until '0.5' is displayed. (0.5 seconds i.e. 2 display updates per second). Enter the revised time and return to the 'UPdAtE' prompt in the main menu by pressing *E*.

Step 3 Select the type of input

Using the *Up* or *Down* button scroll through the main menu until 'InPut' is displayed, then press *P* to reveal the existing setting. Select 'COIL', the input for a magnetic pick-off, using the *Up* or *Down* button and return to the 'InPut' prompt in the main menu by pressing *E*.

Note: The BA538C has two pairs of input terminals. 3 & 4 for voltage inputs and 5 & 6 for switch contact, proximity detector or open collector inputs. Ensure that the magnetic pick-off, which has a voltage output, is connected to terminals 3 & 4.

Step 4 Position rate & total decimal points

Select 'd.P.' from the main menu and press *P*. The rate and total displays will be activated with one digit of the total display flashing. Press the *Up* or *Down* push-button until the third least significant digit of the total display and following decimal point are flashing. This gives the required total display resolution of 0.01

Press *P* to move control to the rate display. Using the *Up* or *Down* push-button move the flashing digit to the least significant position (right hand side) which will result in no decimal point being displayed.

Finally press *E* to return to the 'd.P.' prompt in the main menu.

Step 5 Enter the rate scaling factor

Select 'SCALE-r' from the main menu and press *P* to show the current figure. The K factor of the flowmeter in this example is 1050.0* pulses per litre which should be entered as the rate scaling factor.

Firstly to position the decimal point, operate the *P* push-button to move the flashing digit to the second least significant position. Pressing the *Up* and *Down* buttons simultaneously will then position the decimal point in front of the least significant digit.

Using the *Up* and *Down* buttons to adjust each digit in turn and the *P* button to transfer control between digits, enter 1050.0. Finally return to the 'SCALE-r' prompt in the main menu by pressing *E*.

* May also be entered as 1050

Step 6 Enter the rate timebase

Select 't-bASE' from the main menu and press *P* to show the current setting. In this example the rate display is required in litres per hour. Using the *Up* or *Down* button scroll through the three options and select 'tb-3600' which will multiply the rate display by 3600. Return to the 't-bASE' prompt in the main menu by pressing *E*.

Step 7 Adjust the rate filter

The rate display filter parameters should be adjusted experimentally after installation to provide a stable rate display with an acceptable step response.

During commissioning it is recommend that initially the second digit of the rate parameters is set to 0 (step response off) and the first digit (amount of filtering) is adjusted to provide acceptable rate display stability. The second digit should then be increased until acceptable rate display stability is once again achieved.

To adjust the filter parameters select 'FILtEr' from the main menu and press *P* to reveal the current setting. The first digit will be flashing and may be adjusted using the *Up* or *Down* button. The *P* button will transfer control to the second digit. When both are set as required, return to the 'FILtEr' prompt in the main menu by pressing *E*.

Step 8 Enter the total scaling factor

The K factor of the flowmeter in this example is 1050.0 pulses per litre and the total display is required in cubic metres.

There are 1000 litres in a cubic metre so the BA538C is required to display 1 cubic metre for every 1,050 x 1,000 pulses received. 'SCALE-t' should therefore be set to 1,050,000

Select 'SCALE-t' from the main menu and press *P* which will reveal the current setting with one digit flashing. To position the decimal point, operate the *P* push-button to move the flashing digit to the least significant position. Pressing the *Up* and *Down* buttons simultaneously will then remove the decimal point.

Using the *Up* and *Down* buttons to adjust each digit in turn and the *P* button to transfer control between digits, enter 1050000. Finally return to the 'SCALE-t' prompt in the main menu by pressing *E*.

Step 9 Define clip-off

In this example totalisation is to be inhibited at flow rates below 300 litres per hour.

Select 'CLIP-OFF' from the main menu and press *P* which will reveal the clip-off threshold in litres per hour i.e. the same units already selected for the rate display. The most significant digit of the display will be flashing, indicating that this digit may be adjusted. Pressing *P* five times will move the flashing digit to the third least significant digit.

Using the *Up* and *Down* buttons set the third least significant digit to 3 i.e. a clip-off threshold of 300. Finally return to the 'CLIP-OFF' prompt in the main menu by pressing *E*.

Step 10 Turn local reset on

In this example the operator needs to reset the total display to zero by pressing the *Up* and *Down* buttons simultaneously. To activate the local reset function select 'LOC.rSEt' from the main menu and press *P* to display the current setting. Pressing the *Up* or *Down* button will toggle the display between 'On' and 'OFF'. Select 'On' and press *E* to return to the 'LOCrSEt' prompt in the main menu.

Step 11 Reset the grand total to zero

Before completing commissioning the grand total counter should be reset to zero. Select 'CLr. Gtot' from the main menu and press *P* which will cause the instrument to display 'Clr. no'. Toggle this to 'CLr. YES' using the *Up* or *Down* push-buttons and press *P* which will result in a '0000' prompt. Using the *Up*, and *Down* buttons and the *P* button to move to the next digit, confirm the request by entering the password 'SurE'. Note: S is entered as 5. Pressing *E* will then reset the grand total counter to zero and return the instrument to the 'CLr. Gtot' prompt in the main menu.

Step 12 Define the security code

Defining a security code prevents unauthorised access to the programme functions. Select 'COdE' from the main menu and press *P* which will reveal the existing security code. Using the *Up* and *Down* buttons enter the new code 1209 digit by digit. The *P* button will transfer control between digits. When the new code has been entered, press *E* to return to the main programme menu.

Step 13 Return to the display mode

Following completion of programming and calibration, return the BA538C to the operating mode by pressing *E*. All the programming functions will now be stored in permanent memory and will be protected from accidental or unauthorised adjustment by the security code.

7. MAINTENANCE

7.1 Fault finding during commissioning

If a BA538C fails to function during commissioning the following procedure should be followed:

Symptom	Cause	Check:
No display	Incorrect wiring Note: Terminals 2, 4, 6 & 8 are interconnected within the BA538C	That there is between 10 and 30V on terminals 1 & 2 with terminal 1 positive.
Flow indicator not rotating	No input pulses, incorrect input terminals used, or incorrect type of input selected	That BA538C has been calibrated for the correct input. That input signal polarity is correct.
Flow indicator rotating but incorrect rate display	Incorrect calibration Input below clip-off threshold	That rate scale factor and timebase are correctly programmed. That clip-off threshold is set correctly.
Unstable rate display	Noisy pulse input signal	Source of electrical noise and try to eliminate or increase rate filter.
Correct rate display but incorrect total display	Incorrect calibration Remote reset switch contacts closed	That total scale factor is correctly programmed. That 'RESET' annunciator is not activated. If it is, check reset wiring and switch.
Unable to enter programme mode	Incorrect security code	That the correct security code is being used, or fit security link in override position. See Fig 7
Clip-off does not function and 4/20mA output is constantly 3.5mA	Clip-off & 4/20mA have been automatically reset to zero following change of rate display calibration	Re-enter required clip-off and 4/20mA output calibration.
Alarms do not function	Alarms have been disabled following calibration change	Re-enable both alarms.

7.2 Fault finding after commissioning

ENSURE PLANT SAFETY BEFORE STARTING MAINTENANCE

If a BA538C fails after it has been functioning correctly, the following table may help to identify the cause of the failure.

Symptom	Cause	Check:
No display	No power supply.	That there is between 10 and 30V on terminals 1 & 2.
Flow indicator not rotating	No input pulses	Output from flowmeter Wiring between flowmeter and BA538C
Flow indicator rotating, but rate display indicates zero and there is no totalisation	Input below clip-off threshold	Clip-off threshold and if necessary adjust.
Unstable rate display	Noisy pulse input signal	Source of electrical noise and try to eliminate, or increase rate filter.

If this procedure does not reveal the cause of the fault, it is recommended that the instrument is replaced.

7.3 Servicing

We recommend that faulty BA538C rate totalisers are returned to BEKA associates or to our local agent for repair.

7.4 Routine maintenance

The mechanical and electrical condition of the instrument should be regularly checked. Initially annual inspections are recommended, but the inspection frequency should be adjusted to suit environmental conditions.

7.5 Guarantee

Instruments which fail within the guarantee period should be returned to BEKA associates or our local agent. It is helpful if a brief description of the fault symptoms is provided.

7.6 Customer comments

BEKA associates is always pleased to receive comments from customers about our products and services. All communications are acknowledged and whenever possible, suggestions are implemented.

8. ACCESSORIES

8.1 Scale card

The BA538C has a window on the right hand side of the display to hold a card showing the units of measurement e.g. Litres, Gallons, m³. Instruments can be supplied with a printed scale card showing any units specified at the time of ordering. If a printed card is not requested, a blank card will be supplied.

Scale cards can easily be marked on-site as follows:

- Remove the rear terminal block(s) and the rear panel as shown in Fig 7.
- Carefully pull the rate totaliser assembly from the enclosure.
- Gently pull and then slide the blank scale card towards the display window until the card is free. Mark the card with the required legend and replace in the slot.
- Reassemble the instrument.

8.2 Tag number

The BA538C can be supplied with a thermally printed tag number on the rear panel. This tag number is not visible from the front of the instrument after installation.

8.3 Alarms

The BA538C can be supplied with two solid state single pole outputs which may be independently programmed as high or low, rate or total alarms with normally open or normally closed outputs.

WARNING

These alarm outputs should not be used for critical safety applications such as a shut down system.

When the BA538C power supply is turned off or disconnected, both BA538C alarm outputs will open irrespective of whether normally open or normally closed outputs have been selected. When designing a system an open output should therefore be the alarm condition.

Alarm annunciators on the instrument display indicate the status of both alarms. If an alarm delay or silence time has been selected the annunciator will flash during the delay or silence period.

Programmable functions for each alarm include adjustable setpoint, alarm delay time and alarm silence time. Hysteresis may be applied to rate alarms.

The BA538C total display is up-dated and compared with the programmed alarm setpoint twice per second, irrespective of the display update time selected. This may result in the total alarm being delayed for up to half a second after the total has exceeded the setpoint.

8.3.1 Solid state output

Each alarm has a galvanically isolated single pole solid state switch output as shown in Fig 8. The outputs are polarised and current will only flow in one direction. Terminals A1 and A3 should be connected to the positive side of the supply.

$$\begin{aligned} R_{on} &= 5\Omega + 0.6V \\ R_{off} &= \text{greater than } 180k \end{aligned}$$

Note: Because of the series protection diode some test meters may not detect a closed alarm output

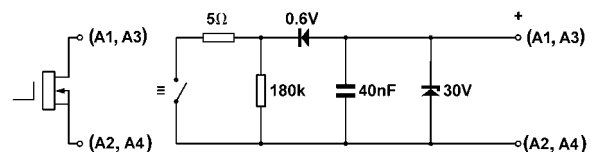

Fig 8 Equivalent circuit of each alarm output

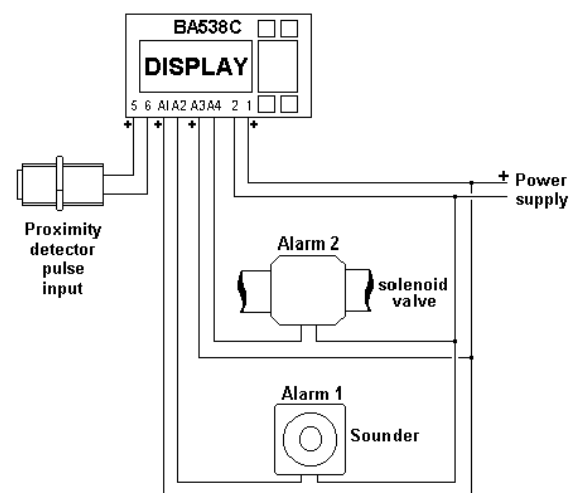

Fig 9 Typical alarm application

8.3.2 Programming and adjustment

When a BA538C is supplied with alarms the main programme menu is extended as shown in Fig 10. The two alarm functions appear between the 'LOC-rSEt' and the 'CLr.Gtot' functions. Each alarm may be programmed as a rate or as a total alarm.

For simplicity Fig 10 only shows the programmable functions on the rate option of alarm AL1. Alarm 2 and the total options are identical except that the total alarms do not have hysteresis.

The following table summarises each of the alarm programme functions and includes a cross reference to more detailed information. Again only the functions on alarm AL1 are listed.

Summary of programmable alarm functions

<u>Display</u>	<u>Description of function</u>
'EnbL'	Alarm enable Enables or disables the alarm function without changing the alarm parameters. See section 8.3.3
'tYPE'	Type of alarm Defines whether the alarm operates on the rate or total display. See section 8.3.4
'SPr1' or 'SPt1'	Alarm setpoint 1 Adjusts the alarm setpoint. The alarm is activated when the rate or total display equals the setpoint. Note: 'SPr1' is displayed for a rate alarm and 'SPt1' for a total alarm. See section 8.3.5
'HI.LO'	Alarm function Defines whether the alarm has a high or low function See section 8.3.6
'no.nc'	Normally open or normally closed output Determines whether the single pole alarm output is open or closed in the non-alarm condition. See section 8.3.7
'HStr'	Hysteresis Adjusts the alarm hysteresis. Only available on rate alarms. See section 8.3.8
'dELA'	Alarm delay time Adjusts the delay between the display equalling the setpoint and the alarm output being activated. See section 8.3.9
'SIL'	Alarm silence time Defines the time that the alarm output remains in the non-alarm condition following acceptance of an alarm. See section 8.3.10
'AcSP'	Access setpoint Sub-menu that enables direct access to the alarm setpoints from the display mode and defines a separate security code. See section 8.3.11

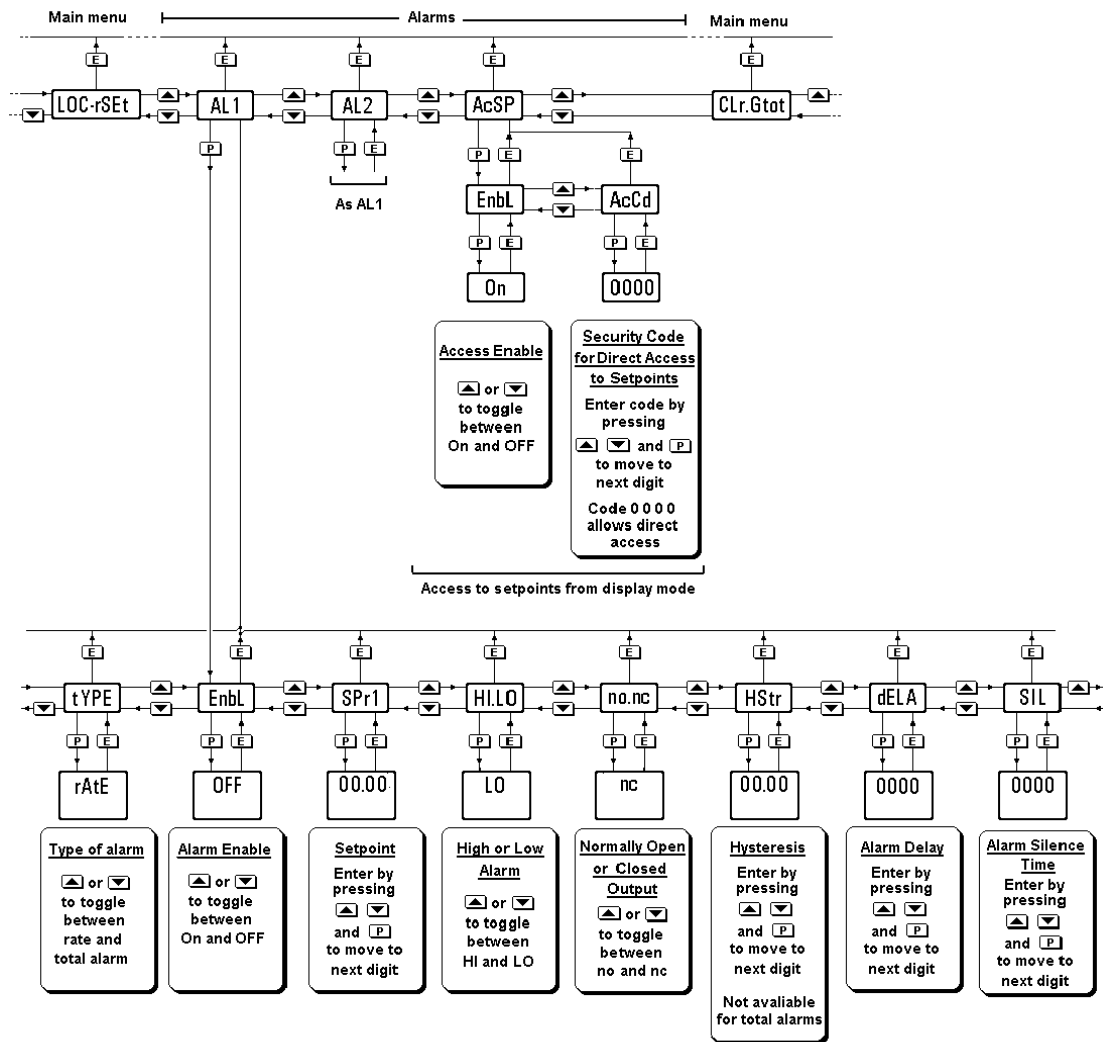

Fig 10 Alarm menu structure

8.3.3 Alarm enable: 'EnbL'

This function allows the alarm to be enabled or disabled without altering any of the alarm parameters. To check or change the function select 'EnbL' from the alarm menu and press *P* which will reveal the current setting. The function can be changed by pressing the *Up* or *Down* button followed by the *E* button to return to the alarm menu.

Note: The alarms will be automatically disabled after the rate or total displays have been recalibrated, or the alarm type has been changed. Both alarms must therefore be enabled after calibration changes.

8.3.4 Type of alarm: 'tYPE'

Alarm 1 and Alarm 2 may both be rate or total alarms, or one may be conditioned for rate and the other for total.

To check or change the type of alarm, select 'tYPE' from the alarm menu and press *P* which will reveal the current setting. The function can be changed by pressing the *Up* or *Down* button followed by the *E* button to return to the alarm menu.

Note: When 'tYPE' is changed, the alarm parameters are automatically set to the default values and the alarm disabled. It must therefore be reprogrammed before use.

8.3.5 Setpoint adjustment: 'SPx1' and 'SPx2'

The rate alarm setpoints SP_{r1} and SP_{r2} may be positioned anywhere between 0 and 999999, and the total alarm setpoint SP_{t1} and SP_{t2} anywhere between 00000000 and 99999999.

To adjust the setpoint of alarm 1 select 'SP_{r1}' or 'SP_{t1}', depending upon how it has been programmed, from the alarm menu. Press *P* which will reveal the existing value with one digit flashing. Each digit of the setpoint can be adjusted using the *Up* and *Down* push-buttons, and the *P* button to move to the next digit. The position of the decimal point is defined by the d.P. function which should be set first. When the required value has been entered press *E* to return to the alarm menu.

Note: 'SP_{r1}' is displayed when alarm 1 has been programmed as a rate alarm and 'SP_{t1}' when programmed as a total alarm.

8.3.6 Alarm function: 'HI.LO'

Each alarm must be conditioned as a high or low alarm. To check or change the alarm function select 'HI.LO' from the alarm menu and press *P* to reveal the current setting. The function can be changed by pressing the *Up* or *Down* buttons followed by the *E* button to return to the alarm menu.

8.3.7 Alarm output status: 'no.nc'

The two alarm outputs may be open or closed in the non-alarm condition. When the BA538C power supply is turned off or disconnected, both the alarm outputs will open irrespective of whether normally open or normally closed outputs have been selected. Therefore, when designing an alarm system normally closed 'nc' should be selected so that the output opens when an alarm occurs or if the power supply fails.

To check the alarm output status select 'no.nc' from the alarm menu and press *P* to reveal the current setting. The function can be changed by pressing the *Up* or *Down* button followed by the *E* button to return to the alarm menu.

8.3.8 Hysteresis: 'HStr'

Hysteresis is only available on rate alarms. During programming hysteresis is shown in the units of rate the BA538C has been calibrated to display.

To adjust the hysteresis, select 'HStr' from the alarm menu and press *P* which will reveal the existing figure. Each digit can be adjusted using the *Up* and *Down* push-buttons, and the *P* button to move to the next digit. When the required hysteresis has been entered, press *E* to return to the alarm menu.

e.g. A BA538C calibrated to display a flow of 0 to 5000, with a high alarm set at 4000 and hysteresis of 100 will perform as follows:

High alarm will be activated when flow equals or exceeds 4000, but will not reset until the flow falls below 3900.

8.3.9 Alarm delay: 'dELA'

This function enables activation of the alarm output to be delayed for a fixed time following the alarm condition occurring. The delay can be programmed in 1 second increments up to 3600 seconds. If a delay is not required zero should be entered. To adjust the delay select 'dELA' from the alarm menu and press *P* which will reveal the existing delay time. Each digit of the delay can be adjusted using the *Up* and *Down* push-buttons, and the *P* button to move to the next digit. When the required delay has been entered, press *E* to return to the alarm menu.

The alarm annunciator will start flashing immediately an alarm occurs and continue for the delay time after which the alarm output will be activated.

8.3.10 Alarm silence time: 'SIL'

The alarm silence function is primarily intended for use in small installations where the alarm output directly operates an annunciator such as a sounder. When the alarm silence time is set to any figure other than zero, the *P* push-button becomes an alarm accept button.

After an alarm has occurred, operating the *P* button will cause the alarm output to revert to the non-alarm condition for the programmed alarm silence time. When an alarm is silenced the alarm annunciator will flash until the silence time expires.

To adjust the silence time select 'SIL' from the alarm menu and press *P* which will reveal the existing time. The time may be adjusted to between 0 and 3600 seconds in 1 second increments. Each digit can be adjusted using the *Up* and *Down* push-buttons, and the *P* button transfers control to the next digit. When the required time has been entered press *E* to return to the alarm menu.

8.3.11 Access Setpoint: 'AcSP'

This function activates a separate menu that provides direct access to the alarm setpoints when the instrument is in the display mode. See section 8.3.12 for a full description. An operator may therefore adjust the alarm setpoints without having access to the programme and alarm menus. Further protection is provided by a separate security code.

This direct access menu may be enabled and a separate security code entered from the 'AcSP' function in the main programme menu as shown in Fig 10. To change the menu parameters select 'AcSP' from the programme menu and press *P*. This will display the enable prompt 'EnbL'.

Press *P* again to reveal if the direct access menu is 'On' or 'OFF'. The *Up* or *Down* buttons will toggle the display between the two conditions.

If 'OFF' is selected, the operator will not have access to the setpoints from the display mode. Return to the 'AcSP' prompt in the main menu by pressing *E* twice.

If 'On' is selected, the operator will have direct access to the alarm setpoints from the display mode via a separate optional security code. To define this four digit numeric code press *E* to return to the 'EnbL' prompt followed by the *Up* or *Down* button to select the access code prompt 'AcCd'. Pressing *P* will then reveal the current security code. The flashing digit of the code may be changed by operating the *Up* or *Down* push-buttons and pressing the *P* button will transfer control to the next digit. When the required code has been entered, press *E* twice to return to the 'AcSP' prompt in the programme menu.

Entering code 0000 will disable the security code allowing direct access to the setpoints in the display mode by pressing the *P* and *Up* buttons simultaneously.

New instruments with alarms are supplied with the security code set to 0000

8.3.12 Adjusting alarm setpoints from the display mode

Access to the two alarm setpoints from the instrument display mode is obtained by operating the *P* and *Up* push-buttons simultaneously as shown in Fig 11. If the setpoints are not protected by a security code the alarm setpoint prompt 'SPr1' or 'SPt1' will be displayed depending upon whether a rate or total alarm has been programmed. If the setpoints are protected by a security code, 'COde' will be displayed first. Pressing *P* again will enable the alarm security code to be entered digit by digit using the *Up* and

Down buttons to change the flashing digit and the *P* push-button to move control to the next digit. If the correct code is entered pressing *E* will then cause alarm setpoint prompt 'SPx1' to be displayed. If an incorrect security code is entered, or a button is not pressed within ten seconds, the instrument will automatically return to the display mode.

Once within the menu pressing the *Up* or *Down* buttons will toggle the display between the two alarm setpoint prompts 'SPx1' and 'SPx2'.

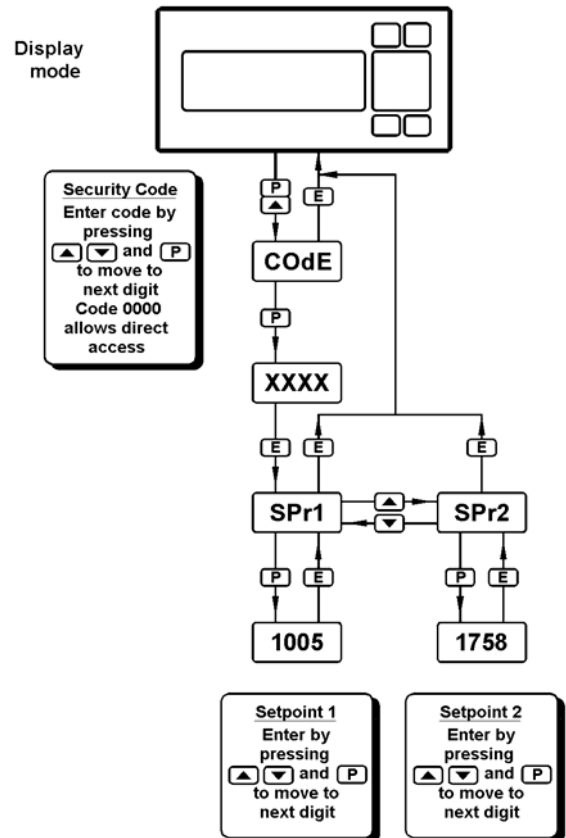

Fig 11 Setpoint adjustment from the display mode

To adjust an alarm setpoint select 'SPx1' or 'SPx2' and press *P* which will reveal the current setting. Each digit of the setpoint may be adjusted using the *Up* and *Down* push-buttons, and the *P* button to move control to the next digit. When the required setpoint has been entered, pressing *E* will return the display to the 'SPx1' or 'SPx2' prompt from which the other setpoint may be selected, or the indicator may be returned to the display mode by pressing *E* again.

Note: Direct access to the alarm setpoints is only available when the menu is enabled - see section 8.3.11

8.4 Display backlight

The BA538C can be supplied with LED backlighting to improve display contrast when the instrument is installed in a poorly illuminated area. The backlight is electrically segregated from the measuring circuit and may be powered from any 18 to 30V dc supply.

Reducing the supply below 18V, or fitting a current limiting resistor in series with the backlight supply will reduce the display brilliance.

Fig 12 shows how the backlight may be powered from the instrument supply.

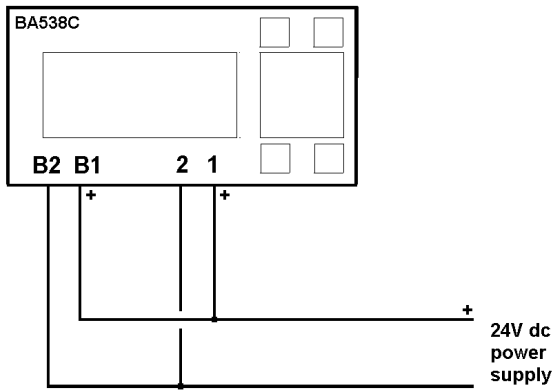

Fig 12 Display backlight

8.5 Pulse output

The BA538C may be supplied with an opto-isolated solid state pulse output. The output is a polarised current sink that closes for a programmable duration each time the least significant digit of the BA538C display changes. A programmable divider enables the pulse output frequency to be divided by 10, 100, 1,000 or 10,000. See Fig 13.

The output pulse is not synchronous with the pulse input to the BA538C. The maximum output pulse frequency is determined by the programmed pulse width.

$$\text{Max frequency} = \frac{1}{2 \times (\text{pulse duration})} \text{ Hz}$$

If the instrument power supply fails or is disconnected, any untransmitted output pulses will be lost.

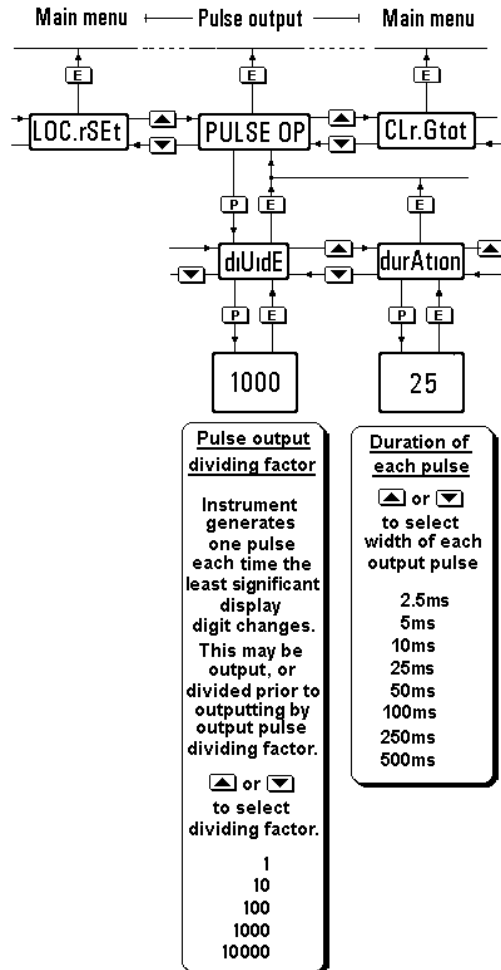

Fig 13 Pulse output menu

The pulse output will sink up to 10mA. When closed the voltage between the pulse output terminals P1 & P2 will be less than 3V when switching 5mA.

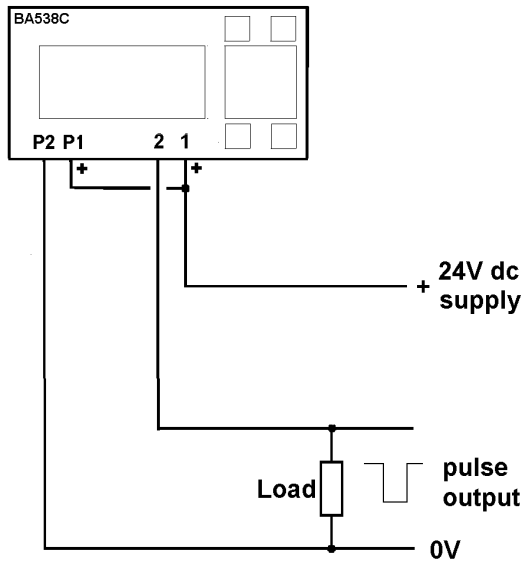

Fig 14 Typical application of pulse output

8.6 4/20mA output

The optional 4/20mA output may be programmed to produce an analogue output proportional to the whole or part of the rate display. The output is a current sink which requires between 5 and 30V to function as shown in Fig 15.

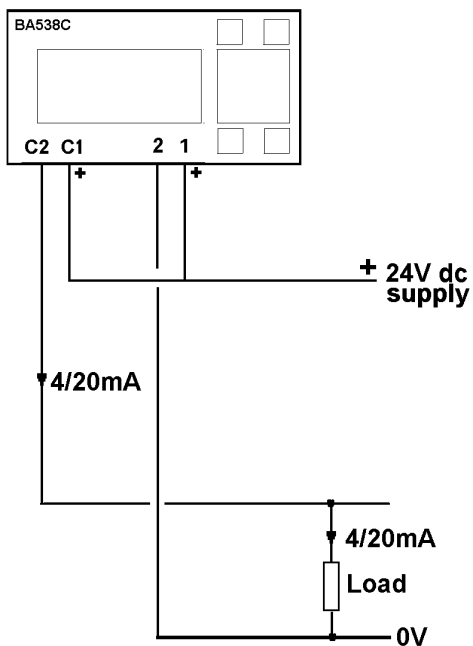

Fig 15 Application of 4/20mA output

8.6.1 Programming and adjustment

The main programme menu is extended as shown in Fig 16 to accommodate the 4/20mA calibration functions.

The '4-20 OP' programme function allows the 4/20mA output current to correspond to any rate display. e.g. 4mA could represent 10 litres/minute and 20mA 100 litres/minute.

To calibrate the 4/20mA output current, enter the programme mode by operating the *P* and *E* push-buttons simultaneously. If the instrument is not protected by a security code the first parameter 'UPdAtE' will be displayed. Enter the security code if the instrument is protected.

Using the *Up* or *Down* push button select the function '4-20 OP' and press *P* which will result in the BA538C displaying '4.000' which is the prompt for setting the rate display corresponding to an output current of 4.000mA. Pressing *P* will reveal the existing setting with the most significant digit flashing. The decimal point will be fixed in the position already defined for the rate display by the 'd.P' function. The value of the flashing digit may be changed by pressing the *Up* or *Down* buttons. When this digit is set as required, pressing *P* will transfer control to the next digit.

When the flow rate corresponding to an output current of 4mA has been entered, press the *E* button to return to the '4.000' prompt.

To enter the rate display corresponding to an output current of 20.000mA, press the *Up* or *Down* button to select the '20.000' prompt followed by *P* to reveal the current setting. This may be changed in the same way as the 4mA setting. When set as required, press *E* three times to return to the display mode via the '20.000' and '4-20 OP' prompts.

The 4/20mA output may be calibrated to increase or decrease as the rate display increases, and most instruments will produce a linear output between 3.5 and 22mA.

Note 1: If the rate display calibration is changed by adjusting the rate scale factor SCALE-r, the timebase t-bASE, or the position of the rate display decimal point, the 4/20mA output will automatically be set to give a constant 3.5mA output irrespective of the rate display. The 4/20mA output must therefore always be recalibrated following recalibration of the rate display.

Note 2: If the BA538C and the 4/20mA current sink output are powered from separate supplies, the 4/20mA output current will continue to flow when the BA538C supply fails or is turned off. Powering both from a common supply as shown in Fig 15 eliminates this effect.

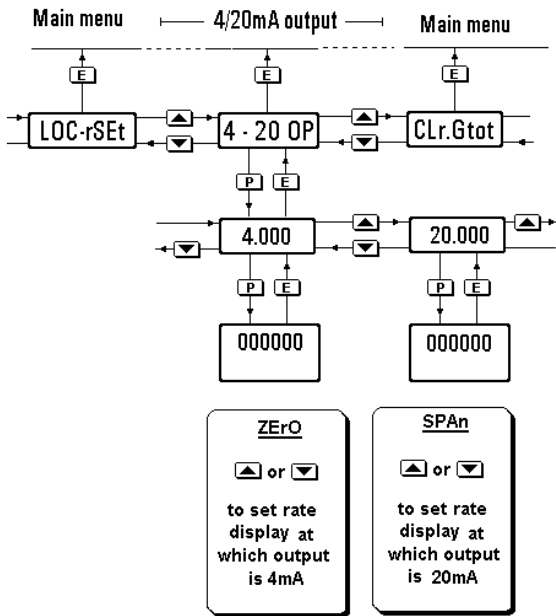

Fig 16 4/20mA output programme structure

9. INDEX

Subject	Section	Subject	Section
'AcSP'	8.3.2; 8.3.11	'LOC.rSEt'	5.13
Alarms optional	8.3	Local reset	5.13
access	8.3.2; 8.3.11	Location	4.1
contacts	8.3.2; 8.3.7		
delay time	8.3.2; 8.3.9	Maintenance	7.0
enable	8.3.2; 8.3.3	routine	7.4
function	8.3.2; 8.3.6		
hysteresis	8.3.2; 8.3.8	'no.nc'	8.3.2; 8.3.7
programming	8.3.2		
setpoint	8.3.2; 8.3.5	Output	
silence time	8.3.2; 8.3.10	Pulse	8.5
solid state output	8.3.1	4/20mA	8.6
type	8.3.2; 8.3.4		
Backlight optional	8.4	Push-buttons	
Calibration		<i>Down</i>	2.2
structure	5.1; Fig 6	<i>E</i>	2.2
programme access	5.2	<i>P</i>	2.2; 8.3.10
example	6	<i>Up</i>	2.2
'CLIP-OFF'	5.12	Rate	
Clipoff	5.12	display	2.3
'CodE'	5.15	scale factor	5.8
		filter	5.10
		Reset	
Decimal points	5.6	local	5.13
'dELA'	8.3.2; 8.3.9	remote	3.4
Display	2.3		
backlight	8.4	Scale card	8.1
exchange rate & total	5.6	'SCALE-r'	5.8
lower	5.7	'SCALE-t'	5.11
update time	5.4	Security code	5.15
'dISPLAY.2'	5.7	Servicing	7.3
'd.P.'	5.6	'SIL'	8.3.2; 8.3.10
		'SPxx'	8.3.2; 8.3.5
'EnbL'	8.3.2; 8.3.3		
Fault finding		't-bASE'	5.9
during commissioning	7.1	Terminal numbers	Fig 4
after commissioning	7.2	Timebase	5.8
'FILtEr'	5.10	Total	
Flow indicator	2.3	display	2.3
		scale factor	5.11
Grand total	2.3	'tYPE'	8.3.2; 8.3.4
clear	5.14	Type of input	5.5
Guarantee	7.5		
		'UpdAtE'	5.4
'HI.LO'	8.3.2; 8.3.6		
'HStr'	8.3.2; 8.3.8		
'InPut'	5.5		
Installation	4.2		